



**LEGACY ELITE II**  
2026 OWNER'S MANUAL



# TABLE OF CONTENTS

## INTRODUCTION

INTRODUCTION . . . . .	1
COMPONENT INSTRUCTIONS & ONLINE RESOURCES . . . . .	1
SAFETY INFORMATION . . . . .	1
WEIGHT RATINGS . . . . .	1
FEDERAL CERTIFICATION TAG . . . . .	1
INCLUDED ACCESSORIES . . . . .	2
LEGACY ELITE II SPECIFICATIONS . . . . .	2

## WARRANTY INFORMATION

WHAT IS COVERED . . . . .	3
WARRANTIES . . . . .	3
LIMITATIONS OF LIABILITY . . . . .	3
WHAT IS NOT COVERED . . . . .	3
INDEMNIFICATION BY BUYER . . . . .	3
CHANGES AND IMPROVEMENTS . . . . .	3
OWNER OBLIGATIONS . . . . .	4
HOW TO OBTAIN SERVICE . . . . .	4
WARRANTY AUTHORIZATION . . . . .	4

## SAFETY

LIQUEFIED PETROLEUM (LP) SYSTEM SAFETY. . . . .	5
ALARMS . . . . .	6
FIRE EXTINGUISHER . . . . .	6
FIRE SAFETY. . . . .	6
REAR WINDOW EMERGENCY EXIT . . . . .	7
REPORTING SAFETY DEFECTS . . . . .	7

## TOWING & SETUP

TOWING VEHICLE REQUIREMENTS . . . . .	8
DRIVING TIPS. . . . .	8
LOADING & WEIGHT DISTRIBUTION . . . . .	9
COUPLING. . . . .	11
BREAKAWAY SWITCH . . . . .	11
BRAKE CONTROLLER . . . . .	12
ELECTRICAL JACK STABILIZATION SYSTEM . . . . .	13
BRAKING & BURNISHING BRAKES. . . . .	13
PARKING ON A SLOPE . . . . .	13
TOWING CHECKLIST. . . . .	14
SETUP CHECKLIST . . . . .	14

## ELECTRICAL

OVERVIEW . . . . .	15
CONNECTING TO SHORE POWER . . . . .	15

CONNECTING TO A GENERATOR . . . . .	15
SURGE PROTECTOR . . . . .	15
BATTERY COMPARTMENT . . . . .	15
BATTERY SAFETY. . . . .	16
12-VOLT BATTERY SYSTEM. . . . .	16
STANDARD 12-VOLT BATTERIES . . . . .	16
SMART CHARGE WIZARD . . . . .	16
INVERTER / CHARGER . . . . .	17
SOLAR PACKAGE. . . . .	18
AGM BATTERIES . . . . .	18
LITHIUM BATTERIES. . . . .	19
CIRCUIT BREAKERS . . . . .	20
120V PANEL STANDARD CONFIGURATION . . . . .	20
120V PANEL 2,000W INVERTER CONFIGURATION . . . . .	21
120V PANEL 3,000W INVERTER CONFIGURATION . . . . .	21
12V FUSES. . . . .	22
12V PANEL CONFIGURATION . . . . .	22
ADDITIONAL BREAKERS & FUSES . . . . .	23
OUTLETS & CHARGING STATIONS. . . . .	23
LIGHTING & SWITCHES . . . . .	24

## PLUMBING

OVERVIEW . . . . .	25
PLUMBING SYSTEM – CURBSIDE ACCESS PANEL. . . . .	25
PLUMBING SYSTEM COMPONENTS & VALVES. . . . .	25
WATER PUMP & ACCUMULATOR . . . . .	26
TANK MONITORING . . . . .	26
CITY WATER INLET. . . . .	26
FRESHWATER INLET . . . . .	27
DRAINING THE FRESHWATER TANK . . . . .	27
REAR WATER INLET . . . . .	27
WATER HEATER. . . . .	27
FAUCETS & SHOWER . . . . .	27
TOILET . . . . .	28
BACK-FLOW PREVENTER . . . . .	28
DUMPING WASTE . . . . .	28
WATER SYSTEM TROUBLESHOOTING. . . . .	30
TERMINATION VALVE MAINTENANCE . . . . .	30
WINTERIZATION . . . . .	30
DE-WINTERIZATION. . . . .	32
SANITIZATION . . . . .	32
DECALCIFICATION OF PLUMBING SYSTEM . . . . .	33
PLUMBING DIAGRAM . . . . .	34

## PROPANE

OVERVIEW . . . . .	35
PROPANE TANK HOUSING . . . . .	35
USING THE REGULATOR. . . . .	35
USING THE QUICK CONNECTS OPTION . . . . .	35
REPLACING OR REMOVING THE TANKS . . . . .	35

## EXTERIOR

ENTRY STEPS . . . . .	36
ENTRY DOOR . . . . .	36
EXTERIOR STORAGE . . . . .	36
AWNING. . . . .	36
STORAGE BASKET . . . . .	37
REAR BUMPER ACCESSORY RECEIVER . . . . .	37
EXTERIOR FOLDING TABLE . . . . .	37

## INTERIOR

MAXXAIR CABIN FAN . . . . .	38
MAXXAIR BATH FAN . . . . .	38
HEATING & COOLING PACKAGES . . . . .	38
TRUMA COMPONENTS & CP PLUS CONTROL PANEL . . . . .	38
DOMETIC THERMOSTAT . . . . .	38
GALLEY. . . . .	38
COUNTERTOPS. . . . .	38
COOKTOP . . . . .	38
REFRIGERATOR . . . . .	38
MICROWAVE . . . . .	38
SHOWER TRACK PACKAGE . . . . .	39
BATHROOM VANITY . . . . .	39
BATH LIGHT . . . . .	39
ENTERTAINMENT SYSTEM . . . . .	39
TELEVISION . . . . .	39
BLUETOOTH SPEAKER. . . . .	39
SEATING & SLEEPING . . . . .	40
DINETTE . . . . .	40
FLOOR PLAN CONFIGURATIONS . . . . .	40

## MAINTENANCE

OVERVIEW . . . . .	41
FIBERGLASS. . . . .	41
FRAMES . . . . .	41
AXLES & SUSPENSION. . . . .	41
SEALS & ADHESIVES . . . . .	41
WINDOWS & DOORS . . . . .	41
DRAINAGE SYSTEM . . . . .	42

UPHOLSTERY . . . . .	42
ELECTRICAL. . . . .	42
PROPANE . . . . .	42
INTERIOR COMPONENTS & SURFACES . . . . .	42
ROOF TOP COMPONENTS . . . . .	42
LIGHTING . . . . .	42
CONDENSATION . . . . .	42
STORING YOUR OLIVER. . . . .	42
TIRES. . . . .	43
LUG NUT TORQUE SPECS. . . . .	43
OWNER AWARENESS . . . . .	43
CHANGING TIRES . . . . .	43
REMOVE SPARE TIRES . . . . .	43
TIRE SAFETY INFO. . . . .	44
DETERMINING CORRECT LOAD LIMIT (TRAILER) . . . . .	44
TRAILERS 10,000 LBS. GVWR OR LESS . . . . .	45
TRAILERS OVER 10,000 LBS. GVWR . . . . .	45
DETERMINING CORRECT LOAD LIMIT (TOW VEHICLE). . . . .	45
GLOSSARY OF TIRE TERMINOLOGY . . . . .	45
TIRE SAFETY. . . . .	47
BASIC TIRE MAINTENANCE. . . . .	48
FINDING YOUR VEHICLES RECOMMENDED TIRE PRESSURE AND LOAD LIMITS . . . . .	48
UNDERSTANDING TIRE PRESSURE & LOAD LIMITS . . . . .	48
MAINTAINING PROPER TIRE PRESSURE . . . . .	48
TIRE SIZE. . . . .	49
TIRE TREAD . . . . .	49
TIRE BALANCE AND WHEEL ALIGNMENTS. . . . .	49
TIRE REPAIR. . . . .	49
TIRE FUNDAMENTALS. . . . .	49
INFORMATION ON PASSENGER VEHICLE TIRES. . . . .	49
UTQGS INFORMATION . . . . .	50
ADDITIONAL INFORMATION ON LIGHT TRUCK TIRES. . . . .	50
TIRE SAFETY TIPS. . . . .	51
MAINTENANCE SCHEDULE. . . . .	51

## *Welcome to the Oliver family!*

Thank you for investing in and starting this journey with Oliver Travel Trailers. We know that you have numerous travel trailer options, but we firmly believe you have made the best choice. We are not only committed to building the best quality travel trailers on the road, but we stand behind them with the best customer service the industry can offer.

To ensure you get the most out of your new trailer, this manual covers common questions and instructions for using it effectively. Whether it's your first time owning a trailer or you're a seasoned traveler, reading through this manual thoroughly will help you experience your vacations with peace of mind. We truly want you to enjoy your Oliver to the fullest and help make your road to vacationing freedom more pleasant and relaxing.

Additionally if you prefer visual learning, Oliver has a library of instructional videos available on our website and YouTube channel. These videos cover everything from basic operations to maintenance tips, ensuring you're well-equipped to handle common challenges you may encounter.

If you have any questions, or need further assistance, don't hesitate to reach out to your nearest Oliver dealer or directly with Oliver travel trailer technical support. At Oliver, we're dedicated to providing support and ensuring your experience with your travel trailer is nothing short of exceptional.





## INTRODUCTION

This manual has been prepared by Oliver Travel Trailers in conjunction with the component manufacturers to provide information and instructions covering the operation and maintenance of your travel trailer. Read all component manuals and validate warranties by mailing the individual warranty cards as some component manufacturers require. Always keep this owner's manual with your travel trailer for easy reference, making sure to comply with all notes and warnings. Before your first trip, become familiar with the components and systems both inside and outside of your Oliver.

This owner's manual is as current as possible at the time your travel trailer was produced. However, since our products are constantly being upgraded and improved, some standard items and/or options may vary. If this occurs, follow the separate component manufacturer's instructions provided in their literature. **We reserve the right to change the construction or material of any part(s) at any time without incurring the obligation to install such changes on delivered units.**

Oliver Travel Trailers is furnishing you with this guideline to assist you through your travels. If further assistance is needed, please contact your nearest dealer.

### COMPONENT INSTRUCTIONS & ADDITIONAL RESOURCES

Some of the equipment shown in this manual may be optional equipment not included or available with your travel trailer. To view specific information about the standard and optional components listed in this manual visit:

[olivertraveltrailers.com/oliver-university](http://olivertraveltrailers.com/oliver-university)



Scan the QR code to access  
**Oliver University** online

We have created a library of videos to help you get familiar with your travel trailer and its components. Please see our Delivery Series videos on YouTube at:

[tinyurl.com/3v5mcr99](http://tinyurl.com/3v5mcr99)



Scan the QR code to view our catalog of  
how-to videos on **YouTube**

### IMPORTANT SAFETY INFORMATION

Throughout this manual, we have placed special emphasis on information that requires your absolute attention. These symbols indicate information that the user must be aware of since failure to heed these cautions or warnings may result in product damage, property damage, serious injury, or death.

 **WARNING**

 **CAUTION**

 **DANGER**

**NOTICE**

### WEIGHT RATINGS

GVWR (Gross Vehicle Weight Rating) - The maximum permissible weight of this trailer when fully loaded, including all weight at the trailer's axle, plus tongue.

GAWR (Gross Axle Weight Rating) - The maximum allowable weight that an axle system is designed to carry.

UVW (Unloaded Vehicle Weight) - The weight of the trailer as manufactured at the factory, includes all the weight of the trailer axle and the tongue.

CCC (Cargo Carrying Capacity) - Equal to GVWR minus each of the following; UVW, full potable water weight and full LP Gas weight.

### FEDERAL CERTIFICATION LABEL

The Federal Certification label is located on the road side near the front of the unit and contains the GVWR, GAWR (front and rear) and tire pressure limits.

### VIN INFORMATION

The Oliver Travel Trailer VIN (Vehicle Identification Number) is located on the driver's side, towards the lower front of the trailer in the area of the reflector.

### SAFETY & INFORMATION LABELS

Labels throughout the trailer will indicate warnings, service instructions and component identification. Be sure to read all warnings and instructions before operating your recreational vehicle.

**INCLUDED ACCESSORIES**

You will receive the following items at delivery:

- › **Owner's Manual**
- › **USB Flash Drive with Component Manuals**
- › **Component Remote Controls**
- › **30-AMP Shore Power Cord**
- › **Lug Wrench**
- › **Manual Jack Wrench**

**ELITE II SPECIFICATIONS**

GVWR	7,000 LBS
DRY WEIGHT (APPROX.)	4,900 LBS
TONGUE WEIGHT (APPROX.)	490 LBS
OUTSIDE LENGTH	24'
OUTSIDE HEIGHT	8' 8"
OUTSIDE HEIGHT (TOP OF A/C UNIT)	9' 8"
OUTSIDE WIDTH	7'
INSIDE HEIGHT	6' 6"
INSIDE WIDTH	6' 7"
FRESH WATER TANK CAPACITY	32 GAL
GREY WATER TANK CAPACITY	32 GAL
BLACK WATER TANK CAPACITY	15 GAL
SEATS	7
SLEEPS	3





## WARRANTY INFORMATION

### WHAT IS COVERED

Oliver Travel Trailers Inc. (Oliver) provides the following limited warranties with its recreational vehicle (RV) which sets forth what Oliver will cover and what Oliver will do if a defect exists. Neither limited warranty is a guarantee about the RV for any period of time. Oliver Travel Trailers are built in accordance with manufacturer's specifications and any modifications not performed by Oliver will potentially void your warranty.

### WARRANTIES

Oliver provides the following limited warranties with its RV, which establishes what Oliver will cover and what Oliver will do if a defect exists:

- ▶ **One-year limited warranty** on all components against defects in material or workmanship.
- ▶ **Two-year limited warranty** on all components manufactured and installed by Oliver against defects in material or workmanship.
- ▶ **Five-year limited warranty** on the fiberglass body and aluminum chassis undercarriage against defects in material or workmanship.

### LIMITATIONS OF LIABILITY

Oliver's liability with respect to products sold hereunder will be limited as provided in the Warranties section and concerning other performance will be limited to the contract price of the portion of the goods on which such liability is Oliver will not be subject to any other obligations or liabilities whatsoever, expressed or implied, whether based on contract, tort, or other theories of law, including implied warranties of merchantability or fitness for any particular purpose, with respect to goods or services furnished by or with respect to any undertakings, acts, or omissions related thereto.

Without limiting the generality of the foregoing, Oliver expressly disclaims any liability for property or personal injury damages, penalties, special or punitive damages, damages for lost profits, loss of use of equipment, cost of capital, cost of substitute products, facilities, or services, or any other type of economic loss or claim. Oliver will not be liable for any damages as a result of any delay or failure to timely deliver for any reason.

Oliver specifically disclaims all consequential, incidental, and contingent damages whatsoever.

### WHAT IS NOT COVERED

This Limited Warranty does not provide coverage for any of the following:

- ▶ Oliver RV's are manufactured for recreational purposes only and are not intended for commercial, residential, or rental purposes. Use for these purposes will void the warranty.
- ▶ Oliver warranty is only extended to the original Buyer, is not transferable, and begins on the date of original retail delivery
- ▶ Normal deterioration due to wear or exposure, including but not limited to rust, corrosion, oxidation, and cosmetic blemishes.
- ▶ Normal maintenance and service items. Examples include but are not limited to bulbs, fuses, lubricants, tires, etc.
- ▶ After-market equipment or accessories installed after completion of manufacture by Oliver, or any defects or damage caused by such items.
- ▶ Defects or damage caused by, in whole or in part, or in any way related to: Accidents, misuse (including off-road use), or negligence.
- ▶ Failure to comply with instructions and maintenance schedules outlined in owners and component manuals.
- ▶ Alteration or modification of the RV.
- ▶ A force majeure such as acts of God; war; civil commotion; fire, flood, inclement weather; government regulations; pandemics or epidemics; or other causes reasonably beyond Oliver's control.
- ▶ Chemicals applied to the RV.
- ▶ Condensation and the results of condensation.
- ▶ Improper electric power supply.
- ▶ Acts or omissions of any person or entity other than Oliver.

### INDEMNIFICATION BY BUYER

Buyer will indemnify and hold Oliver harmless from and against any and all losses, damages, legal fees, or expenses of Buyer in whatever form or nature arising out of or in connection with the products sold to Buyer if Oliver is proven to have no cause in the occurrence. This provision does not limit in any way any term, feature, or benefit specified in the Warranties.

### CHANGES AND IMPROVEMENTS

Oliver may furnish suitable substitutes for materials or goods unobtainable because of priorities or regulations established by governmental authority or the unavailability of material or goods from suppliers.





Oliver has no obligation to furnish the Buyer with changes in the design or construction of goods previously shipped despite the incorporation of such changes in current shipments. If the particular model of goods ordered by the Buyer has been replaced by a new model, Oliver may at its option ship the new model of such goods.

### OWNER OBLIGATIONS

The owner is responsible for all maintenance and upkeep. If a problem occurs which the owner believes is covered by this warranty, the owner shall contact an Oliver dealer, giving them sufficient information to resolve the matter.

The owner is responsible for transport of camper to and from service center for repairs. The owner is also responsible for inspection and maintenance of all seals and joints. (i.e. doors, windows, air units, satellite, television cable connections, plumbing, etc.)



### WARNING

The owner's failure to perform such inspections and maintenance which results in water damage or any other damage shall void the warranty.

It is the owner's responsibility to notify an Oliver dealer of a defect in a timely manner. Failure to notify promptly will void all or portions of the limited warranty.

This warranty gives you specific legal rights, and you may also have other rights, which vary from state to state. Dealers or any other persons are not authorized to make modifications to this warranty. Any additional statements concerning this warranty, whether oral or written, are not the responsibility of the manufacturer and should not be relied upon.

### HOW TO OBTAIN SERVICE

To obtain service on your travel trailer under this Limited Warranty, contact your nearest Oliver Travel Trailer Dealership or contact our Oliver Customer Support Department at **1-888-526-3978**.

Or visit our service portal to submit a Service Ticket at: [support.olivertraveltrailers.com/portal/en/newticket](https://support.olivertraveltrailers.com/portal/en/newticket)



Scan the QR code to access our service portal online

### WARRANTY AUTHORIZATION

For the Buyer to claim any warranty, the Buyer must contact an Oliver Travel Trailer Dealership to obtain authorization for repairs to be made under warranty. **Warranty repairs made without authorization may be subject to denial or partial payments.** All costs associated with transporting the RV for warranty service are the responsibility of the owner.



Scan the QR code to access our dealership locator online

Any parts that require replacement that are covered under the terms of the warranty should be retained and returned to the Oliver Travel Trailers Technical support department. Call **1-888-526-3978** to obtain instructions regarding your returns.

Modifications made to your travel trailer without proper authorization can result in reduction or loss of warranty coverage.

### NOTICE

Any warranty repairs to installed components must be made within the designated time frame per the manufacturers' warranty.

Notifying Oliver of a warranty issue but not resolving it through the vendor does not meet warranty coverage requirements, and may result in the vendor not honoring the warranty.

## SAFETY

### LIQUEFIED PETROLEUM (LP) SYSTEM SAFETY

These guidelines are for the safe usage of the LP gas systems and appliances.

The following warnings are posted throughout your recreational vehicle to provide information on the LP gas system. They have been installed not only because of requirements to do so but also as a constant reminder to our customers to exercise proper caution when using or being around LP gas appliances and equipment. We are listing them here so that you may study them and make sure that you and your family understand and follow them.

#### WARNING

**DO NOT** place propane cylinders inside the vehicle. Propane cylinders are equipped with safety devices that relieve excessive pressure by discharging propane in to the atmosphere.

Propane gas is highly flammable. Can lead to a fire or explosion and result in death or serious injury.

A Warning label is located near the LP gas container. This label reads:

#### DANGER

All pilot lights, appliances and their igniters (see operating instructions) shall be turned off before refueling of motor fuel tanks and/or propane containers.

Can cause ignition of flammable vapors, which can lead to a fire or explosion and result in death or serious injury.

#### WARNING

**DO NOT** fill propane container(s) to more than 80% of capacity. A properly filled container contains approximately 80% of its volume as liquid propane.

Overfilling the propane container(s) can result in uncontrolled propane flow, which could lead to a fire or explosion and result in death or serious injury.

#### WARNING

This propane piping system is designed for use with propane only. **DO NOT** connect natural gas to this system.

Securely cap inlet when not connected for use. After turning on propane, except after normal cylinder replacement, test propane piping and connections to appliances for leakage with soapy water or bubble solution.

**DO NOT** use products that contain ammonia or chlorine to test for leaks. Can lead to a fire or explosion, which could result in death or serious injury.

#### WARNING

The propane regulator must always be installed with the regulator vent facing downward.

The propane regulator cover must be kept in place to minimize vent blockage that could result in excessive propane pressure causing fire or explosion.

#### WARNING

**DO NOT** store any items that emit a spark or a flame in the compartment. Failure to adhere to this warning may cause an explosion resulting in personal injury or death.

All items must be completely secured.

#### DANGER

If you smell propane

1. Extinguish any open flames, pilot lights and all smoking materials.
2. Shut off the propane supply at the container valve(s) or propane supply connection.
3. Do not touch electrical switches.
4. Open doors or other ventilating openings
5. Leave the area until the odor clears.
6. Have the propane system checked and leakage source corrected before using again.

Ignition of flammable vapors could lead to a fire or explosion and result in death or serious injury.

## ALARMS

Your trailer is equipped with two safety alarms; a LP/CO Alarm and a Smoke/CO Alarm. You will see the following warning below the Smoke/Co Alarm.



### WARNING

**Test smoke alarm operation after vehicle has been in storage, before each trip, and at least once per week during use. Failure to do so can result in death or serious injury.**

For operating instructions and troubleshooting, view the manufacturer's manual.

## FIRE EXTINGUISHER

In the case of a fire, you will find a Fire Extinguisher mounted on the exterior of the closet door. For operating instructions and troubleshooting, view the manufacturer's manual.

## FIRE SAFETY



### WARNING

**Do not use portable fuel burning equipment, including wood and charcoal grills and stoves, inside the recreational vehicle because the use of such equipment inside the recreational vehicle can cause fires or asphyxiation. Failure to do so can result in death or serious injury.**

Fire safety is an important part of owning a recreational vehicle. The following basic rules of fire prevention can reduce the possibility of a fire.

Make sure that everyone in your recreational vehicle is familiar with the location of exits, including the emergency exit window, which is located at the rear of your travel trailer.

Follow safety rules and prevent hazardous situations:

- › Use smoking materials properly. Never smoke in bed.
- › Keep matches or lighters away from children.
- › Keep electrical appliances in good condition and don't overload electrical circuits.
- › Never leave anything cooking on the stove unattended.
- › Keep portable heaters and open flames, like candles, away from flammable materials.
- › Never store flammable liquids in the recreational vehicle.
- › Keep cooking surfaces clean.

- › Never allow children to play with the LP gas or electrical equipment.
- › Never use an open flame as a flashlight.
- › Always repair faulty or damaged wiring and electrical components.
- › Locate and repair LP leaks immediately.
- › Do not allow rubbish to accumulate.
- › Never clean with a flammable liquid.
- › Spray fabrics annually with a flame retardant liquid.

If a fire does start, make sure to follow these basic rules of safety.

1. Have everyone evacuate the recreational vehicle as quickly as possible.
2. After everyone is clear, check the fire to see if you can attempt to put it out. If it is large, (cannot get within 10 feet) or the fire is fuel-fed, get clear of the recreational vehicle and have the fire department handle the emergency.
3. Make sure you know how to use the fire extinguisher. For operating instructions and troubleshooting, view the manufacturer's manual.
4. Feel doors before opening them to see if they are hot. If a door is cool, open it slowly and check for fire and heat before you proceed. **DO NOT** open a hot door – use an alternate escape route. Stay close to the floor if air is smoky. Take short shallow breaths through a wet cloth if possible.  
**DO NOT** return to your trailer, until fire officials say that it is safe.
5. Once outside, go to your selected meeting place and make sure everyone is there. Call the Fire Department from outside of the travel trailer at a safe location.

## REAR WINDOW EMERGENCY EXIT



### WARNING

**DO NOT operate this RV unless fully set up and emergency exits are accessible. Failure to do so can result in death or serious injury.**

In the event of a fire or other emergency situation and you cannot exit the trailer from the door, you can escape through the Emergency Egress Rear Window

To exit from the egress rear window:

1. Push the TV up to secure it up and under the cabinet to gain access to the rear egress window.
2. Raise the night shade and day shade, exposing the window without a shade in the way.
3. Pull the red handle up out of the latching mechanism.
4. Push the window open and exit the trailer.

## REPORTING SAFETY DEFECTS

If you believe that your vehicle has a defect, which could cause a crash or could cause injury or death, you should immediately inform the National Highway Traffic Safety Administration (NHTSA) in addition to notifying Oliver Travel Trailers.

If NHTSA receives similar complaints, it may open an investigation and if it finds that a safety defect exists in a group of vehicles, it may order a recall and remedy campaign. However, NHTSA cannot become involved in individual problems between you, your dealer or Oliver Travel Trailers.

To contact NHTSA, you may either call the Vehicle Safety Hotline toll-free at:

**1-888-327-4236**

(TTY: 1-800-424-9153)

go to: [www.safercar.gov](http://www.safercar.gov)

or write to:

**Administrator NHTSA  
1200 New Jersey Avenue S.E.  
Washington, DC 20590**

### IN CANADA

If you believe your vehicle has an alleged safety defect, you should contact Transport Canada and our Customer Service Department immediately. To file a safety concern, you can complete an on-line form or call to speak with a defect investigator.



Scan the QR code to access the Defect Complaint Form online

For additional information, please refer to the Transport Canada website at

[www.tc.gc.ca/recalls](http://www.tc.gc.ca/recalls)

To contact Transport Canada by phone:

**1-800-DEFECTS**

**1-819-420-4300** (*Ottawa-Gatineau area or internationally*)

Toll free: **1-800-333-0510** (*in Canada*)

To contact Transport Canada by mail:

**Transport Canada -ASFAD**

**330 Sparks Street**

**Ottawa, ON K1A 0N5**

[www.tc.gc.ca/rappels](http://www.tc.gc.ca/rappels)

Téléphone: **819-994-3328** (*dans la région de Ottawa-Gatineau et à l'extérieur du pays*)

Sans frais: **1-800-333-0510** (*au Canada*)

Adresse postale:

**Transports Canada -ASFAD**

**330, rue Sparks**

**Ottawa (Ontario) K1A 0N5**



## TOWING & SETUP

This section covers coupling, towing, and other important steps to setup your trailer for camping.

### TOWING VEHICLE REQUIREMENTS



#### WARNING

- › **An improperly coupled trailer can result in death or serious injury. Use of a tow vehicle with a towing capacity less than the load rating of the trailer can result in loss of control, and may lead to death or serious injury.**
- › **DO NOT transport people or pets inside the trailer. The transport of people puts their lives at risk and may be illegal.**
- › **Overloaded trailers can result in a loss of control of the vehicle; this could lead to death or serious injury.**
- › **DO NOT exceed the trailers gross vehicle weight (GVWR) or an axles gross axle weight rating (GAWR)**
- › **The proper selection and condition of the coupler and hitch is essential to the safe towing of your trailer. A loss of coupling may result in death or serious injury.**

Before traveling, ensure the following:

- › Replace worn, corroded, or cracked hitch components before coupling the trailer to the tow vehicle.
- › Hitch and tow vehicle are rated for the gross vehicle weight rating (GVWR) of your trailer.
- › The hitch load rating is equal to or greater than the load rating of the trailer coupler.
- › The hitch size is the same as the coupler size.
- › All hitch components are tight before coupling the trailer to the tow vehicle.

### DRIVING TIPS

#### GENERAL

Get to know how your tow vehicle handles with the added weight of your RV. The brakes and steering operation will be different. Before taking a trip practice making right and left turns, braking, backing up, and accelerating.

#### CLEARANCE

Watch for overhanging branches, awnings, or similar obstructions that can damage your vehicle's roof or equipment/accessories mounted on top of it.

### TURNING

Generally, the wheels of your travel trailer are set wider than those of your tow vehicle. To avoid hitting curves or other vehicles, pull several feet farther ahead before turning to allow for this extra width and the length of your travel trailer.

Left turns require a wider than normal swing into the new lane of traffic to keep the trailer from encroaching into the opposing lane. Use turn signals early to communicate to traffic behind and slow down well in advance of any turn.

### PASSING

Avoid sudden maneuvers when passing a slower-moving vehicle. Remember that additional time and distance are required to pass safely. Wait until the road is clear of oncoming traffic.

Check the outside rear-view mirrors and signal lane change before passing. When you have safe clearance, signal lane change and return to your original lane.

### BRAKING

Allow a safe distance to stop; follow no closer than one combined tow vehicle – RV length for each ten mph.

Pump the brake pedal lightly to stop on wet or icy roads. If you start to slide, turn the steering wheel in the direction of the slide. **DO NOT** stomp the brake pedal. A panic stop may increase the slide and could cause your unit to jackknife.

### BACKING

When backing your RV, place your right or left hand at the bottom of the steering wheel. To move your trailer to the left, move your hand to the left; to move the trailer to the right, move your hand to the right. If the trailer starts to jackknife, stop, pull forward, and start again.

### DOWNGRADES

Reduce speed and shift the transmission to a lower gear to assist in braking on long or steep downgrades. Avoid situations that require excessive and prolonged use of the brakes. Apply and release brakes at short intervals to give them time to cool.

### UPGRADES

Reduce speed to 45 MPH. or less when climbing a steep upgrade. Shift the transmission to a lower gear to avoid engine overheating.

**LOADING & WEIGHT DISTRIBUTION**

**PROPER WEIGHT DISTRIBUTION**

Your recreational vehicle has been designed to carry loads within specified limits. Exceeding these limits will greatly affect the handling of the recreational vehicle. These limits are defined in two ways.

**WEIGHT DISTRIBUTION WHEN LOADING**

Towing an Oliver Travel Trailer comes with new challenges and great care and responsibility should be taken when doing so. Oliver has designed a trailer that when towed properly, will be safe and dependable for years to come. It is now up to you to continue safe practices while loading and towing your trailer.

A critical safety issue when towing a trailer is knowing all of the different weights involved and how to properly load your Oliver. The first thing to determine is how much is being towed and determining whether it is within the capacity limit.

It is also critical to determine where to store certain items in the Oliver based on the weight of that item. Distributing the cargo properly is critical to the safety and handling of your Oliver. Make sure your load is balanced. Do not load too much on one side.

Secure all items, as loose items can cause damage and become a safety issue. The cargo carrying capacity is listed on the Tire and Loading Information sticker near the front on the streetside of the trailer.

**CARGO CARRYING CAPACITY**

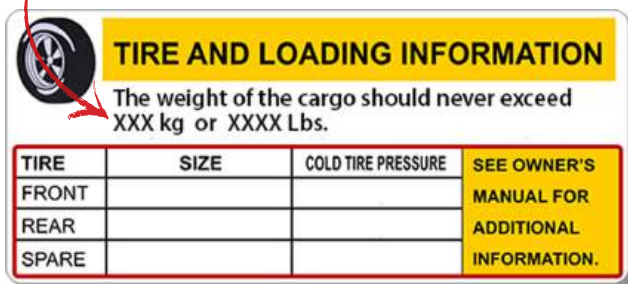

DO NOT assume that you can fill all tanks and all storage areas and be within the GVWR. Weights of stored items will vary greatly and will affect the total weight of your Oliver Travel Trailer.

Always weigh the Oliver at a certified weigh station equipped with platform scales. Check the telephone directory, online, or with local authorities for the location of weigh stations in your area.

If you find that you have exceeded the GVWR of the Oliver, you will have to remove items until you are within specified limits.

Oliver Travel Trailers weighs the trailer when finished to arrive at the vehicle's weight.

That number is subtracted from the GVWR of the trailer and listed under "The weight of the cargo should never exceed" on the tag, the total weight of all cargo, including aftermarket modifications or additions (bike rack hitch/storage basket), water, and propane should never exceed the number listed.

**When loading the trailer, keep the following in mind:**

- › **Gross Vehicle Weight Rating (GVWR)**
- › **Tire Weight Rating**

 **WARNING**

**NEVER** exceed weight ratings. Your safety depends on not overloading the trailer and tires.

**The GVWR for a Legacy Elite II is 7,000 lbs.**

The total weight of your trailer, fully loaded, should never exceed the GVWR. To determine just how much cargo you are safely allowed to load onto your trailer, simply subtract the dry weight of your trailer from the factory from the GVWR.

EXAMPLE:  
 (GVWR) 7,000 lbs. - (Dry Weight) 4,900 lbs.= Cargo 2,100 lbs.

**WEIGHING YOUR OLIVER**

Proper weight and load distribution is essential to safe towing. Common recommendations place approximately 9% to 15% of the loaded weight on a travel trailer hitch. Therefore, if you are towing a 6,000 lbs. trailer, the tongue weight should be measured at approximately 600 lbs. Oliver Travel Trailers confirms that the tongue weight is 9-15% of the dry weight before the trailer leaves the factory.

Too much or too little weight on the hitch leads to dangerous driving conditions such as sway and reduced tow vehicle control. DO NOT exceed the GVWR OR GAWR posted load weights.

Easy weighing of your Oliver, tow vehicle, tongue weight, and tongue weight ratio:

1. Drive your tow vehicle onto the scale but do not drive your trailer axle onto the scale. Record the weight A: (Tow Vehicle Plus Tongue Weight) 7,600 lbs. (See illustration)

2. Pull forward so that both the tow vehicle and the trailer are on the scale. Record the weight B: (Gross Vehicle Weight of Tow Vehicle plus Trailer) 13,000 lbs. (See illustration)
3. Pull tow vehicle off of the scale, disconnect the trailer from the tow vehicle while leaving trailer on the scale. Record the weight: C (Gross Vehicle Weight of Trailer) 6,000 lbs. (See illustration)

Calculate Weight of Tow Vehicle:

$$B \text{ minus } C \text{ equals } D \text{ or } 13,000 - 6,000 = 7,000 \text{ lbs.}$$

Calculate Tongue Weight:

$$A \text{ minus } D \text{ or } 7,600 - 7,000 = 600 \text{ lbs. tongue weight}$$

Calculate Tongue Weight Ratio:

$$\text{Tongue Weight divided by } C \text{ or } 600 / 6,000 = 10\%$$

### STEP 1

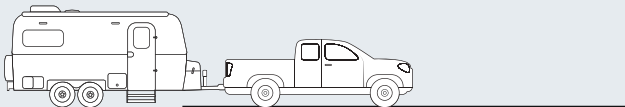

**WEIGHT A: 7,600 LBS**  
(TOW VEHICLE + TONGUE WEIGHT)

### STEP 2

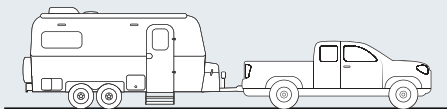

**WEIGHT B: 13,000 LBS**  
(GROSS VEHICLE WEIGHT OF TOW VEHICLE + TRAILER)

### STEP 3

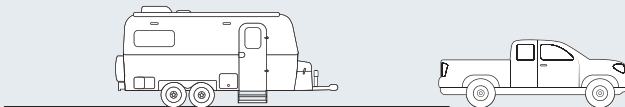

**WEIGHT C: 6,000 LBS.**  
(GROSS VEHICLE WEIGHT OF TRAILER)

Now that you have these weights recorded, check to see if you can safely pull your Oliver with your tow vehicle. The GVW (Gross Vehicle Weight) of the trailer must not exceed 7,000 lbs. Your tongue weight should be between 9-15% of that weight.

If these weights are within regulation then feel free to enjoy the open road.

To locate a public CAT scale in your area, follow this link:  
[www.catscale.com](http://www.catscale.com)

To check out a ball hitch that measures your tongue weight for you, follow this link:  
[www.weigh-safe.com](http://www.weigh-safe.com)

### TRAVEL SUGGESTIONS

It is a good idea to empty the holding tanks before leaving on a trip, and as often as possible when traveling to help keep weight within acceptable limits. A gallon of water weighs about eight pounds, and a full tank weighs about 260 pounds. Try to carry only as much water as you will use when traveling.

All items stored inside and outside the Oliver should be secure, as well as all doors and drawers.

DO NOT add any rack or frame to the Oliver frame or chassis. The alteration may result in unstable handling, be a safety hazard, could damage the Oliver and void your warranties. In any case, the Oliver warranty will be affected.

- ▶ Once you become familiar with loading your trailer, how to distribute the weight, and which items you carry, make a list and diagram you can use for future reference.
- ▶ Plan your loading and storage so that emergency items are easily accessed.
- ▶ Place heavier or breakable items on the travel trailer floor and lowest storage compartments for better load stability.
- ▶ Make sure these items are well packed and secured to prevent movement.
- ▶ Take extra care not to overload the front and rear ends of the trailer. Place any light items in the upper cabinets.
- ▶ Make sure to use packing material around breakable items such as plates and glasses in the cupboards if you will be towing over rough roads or terrain.
- ▶ It is a good idea to use nonskid materials under heavier items to help prevent shifting.
- ▶ Most new trailer owners tend to carry more supplies than they need.
- ▶ It is important to remember that each item added brings extra weight to tow and distribute.

## COUPLING

For operating instructions and troubleshooting, view the manufacturer's manual.

Your Oliver Travel Trailer is equipped with a Class III Bulldog Steel Coupler rated for the GVWR of your trailer. The standard bulldog coupler requires a 2" ball on your tow vehicle. You may have upgraded the bulldog hitch to the 2-5/16" model and will require a 2-5/16" ball.

### CAUTION

Be careful to avoid getting fingers or skin pinched when locking and unlocking the coupler.

## SAFETY CHAINS

After you have the travel trailer coupler properly attached to the hitch ball, the safety chains must be attached. To do so:

1. Cross the safety chains under the tongue and hitch.
2. Attach the hooks to the attachment loops provided on the tow bar portion of the hitch or to the vehicle frame. Do not fasten to any part of the hitch unless the hitch has holes or loops specifically for that purpose.

### NOTICE

If d-links are needed to connect the safety chains to the tow vehicle, each d-link must be rated at 7,000 lbs for Elite II model trailers.

### WARNING

Improper rigging of the safety chains can result in loss of control of the trailer and tow vehicle, leading to death or serious injury.

Do not attempt to repair a damaged cable. If the safety chain has been damaged, it must be replaced.

## BREAKAWAY SWITCH

This switch is designed to engage the trailer's brakes if the trailer were to become disconnected from the tow vehicle. Always be sure to connect the breakaway cable to the tow vehicle when hooking up!

### INSPECTING & TESTING THE BREAKAWAY BATTERY

You should inspect and test the breakaway battery before every use of your trailer.

1. You should inspect the breakaway battery box before every use of your trailer to ensure that it is all intact.

2. You should check the state of your rechargeable battery before every trip.
3. To do this you will push the green "test" button to check the status of the battery.
  - A. If the LED light is GREEN, that indicates the battery is fully charged.
  - B. If the LED light is YELLOW, that indicates the battery is currently charging.
  - C. If the LED light is RED, that indicates the battery is low and needs to be charged.



### INSPECTING & TESTING THE BREAKAWAY SWITCH

You should inspect the breakaway switch periodically to ensure proper function of the product/system. Inspect the wires, cables, and switch box for wear or damage and do a pull test to ensure the pin still comes out and is not broken and the trailer brakes engage when the pin is pulled. If there is any damage or malfunction then replace the damaged components.

1. Visually inspect the electrical wires from the switch box to where they are connected into the battery system and the brake system.

Make sure the wires are not broken or damaged. Make sure the black coating is not damaged and that the copper wire is not exposed anywhere along the wire or at the connection point.

If the wiring is damaged or exposed then replace the switch box and wiring.

2. Visually inspect the breakaway cable. Make sure the cable is not damaged or frayed anywhere along the cable. If damaged, replace the cable.
3. Last, test the function of the breakaway switch system. Before doing this, make sure the trailer electrical plug is not connected to the tow vehicle (or the breakaway system could damage the tow vehicle's trailer brake controller or other electrical systems).

Then, pull the cable near the pin (be careful to prevent recoil of the cable and pin that could cause injury) to remove the pin from the electrical switch box. The pin should pull out with a reasonable amount of pull force.

Inspect the plastic pin to verify it is not broken or damaged. If the pin is too hard to remove (more than 40 lbs pull force) or is loose and comes out too easily or is damaged then replace the pin and cable.





Check that the trailer brakes engage once the pin is removed from the switch. One way to do this is to connect the trailer to the tow vehicle (but leave the trailer electrical plug disconnected from the tow vehicle) and try to gently pull forward with the pin removed from the breakaway switch box. The brakes should engage and prevent the trailer from moving. If the brakes engage and lock the tires, do not try to overpower the brakes by pulling excessively hard with the tow vehicle.

Finally, with the tow vehicle back in park and the park brake engaged, insert the pin back into the breakaway switch box. Do not leave the pin out of the switch box for more than a couple minutes.



### WARNING

- › **DO NOT** leave the pin out of the breakaway switch for more than a couple minutes. This will result in the brakes being continually engaged and may result in damage to the brakes or wiring.
- › Before your trip, ensure your dedicated breakaway battery is fully charged. Your trailer breakaway switch utilizes a dedicated breakaway battery to engage the trailer breaks in the event of an accidental decoupling from the tow-vehicle.

**The breakaway switch will not be able to function as intended without an adequate charge on the batteries.**

**NOTE:** The lack of heavy brake application could be due to the brakes being out of adjustment, low breakaway battery voltage, or a heavily loaded trailer.

The following information is copied from the Zip breakaway cable and switch manual:

- › Loose or corroded connections may cause brake failure. Solder all wire connections.
- › The breakaway switch is connected to the travel trailer's battery system. Low or dead batteries may cause brake failure. Do not use the safety brake system as a parking brake. When parked, secure the trailer with wheel chocks.
- › Test safety brake system for proper operation before each trip. Fatigue and wear may cause shorts or open circuits resulting in brake failure.
- › Obstructions may restrict breakaway pin from being pulled in an emergency. Install switch and couple cable in a location that allows the pin to be freely pulled. Do not feed or loop the cable through safety chain(s).
- › Rigid switch attachment may restrict breakaway pin from being pulled in an emergency. Do not over tighten the installation bolt.

- › Safety chain or hitch ball failure may be the cause of trailer separation. Attach breakaway cable directly to the tow vehicle.



### WARNING

**DO NOT** attach the breakaway cable to safety chains, hitch ball, or ball mount.

A frayed or damaged cable may result in brake failure. Inspect cable before each trip and replace as needed.

### TOW VEHICLE WIRING

It also is necessary to install a proper electrical connection from the tow vehicle to your travel trailer. A car end pigtail has leads of adequate length to allow connection to your tow vehicle wiring system. Make sure that you use wiring of the correct gauge with sufficient slack between the travel trailer and tow vehicle to allow for turning without dragging on the ground. Have your tow vehicle dealer and/or hitch installer assist you with the installation.

The wiring color code for the connections of the trailer to the tow vehicle is as follows:

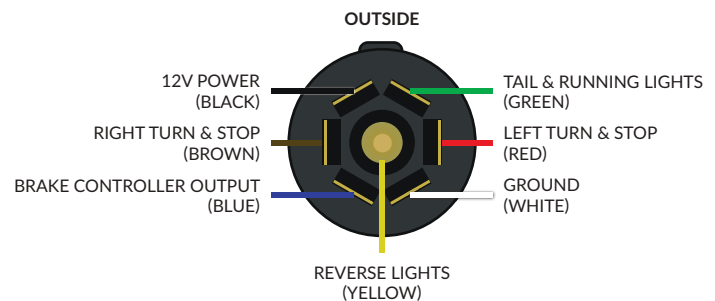

Although your travel trailer has been checked at the factory, we recommend that you visually check to see that all lights are functioning properly before using the trailer.

### 7-PIN ELECTRICAL HOOK-UP

Plug the travel trailer electrical 7-pin connector into the socket located on the tow vehicle. Be sure there is enough slack to prevent disconnection during a full 90° turn.

### 7-PIN MAINTENANCE

Periodically check the 7-PIN to ensure it is clean and dry. Apply dielectric grease on the connectors as needed.

### BRAKE CONTROLLER

Refer to manufacturer for more information on Electronic brake controller adjustment.

**NOTICE**

**A brake controller is required in your tow vehicle which will synchronize your trailer brakes. It may be necessary to adjust the brake controller. Please follow the directions provided by the manufacturer of your brake controller.**

**ELECTRIC JACK STABILIZATION SYSTEM**

For operating instructions and troubleshooting, view the manufacturer's manual. Use the electric stabilization jacks along with wheel chocks and blocks/cribbing to stabilize your trailer.

**WARNING**

**Review all warnings in the manufacturers manual before operating the electric jack stabilization system.**

**ELECTRIC TONGUE JACK**

Located at the front of the frame of the trailer. The jack toggle switch is located below a 3-way float level and next to a night light (which illuminates the hitch work area). With the attached footplate, this jack can raise and lower the front of the trailer for hitching and unhitching on the ball. It also is used in conjunction with the two rear electric stabilizing jacks to stabilize the trailer side-to-side when unhitched.

**REAR ELECTRIC JACKS**

The left and right rear stabilizing jacks are operated from switches mounted inside the basement storage compartment on the street side of the travel trailer. To operate, hold the switch in the position you wish to move the jack; either up or down. When released, the switch will automatically return to its center off position.

**MANUAL JACK OPERATION**

It may be necessary to use the Emergency Hand Crank Wrench if loss of power occurs. This is located in the basement storage or closet at delivery. See our video on YouTube.

**NOTICE**

**If power has been lost, check the 30 AMP slow blow in-line fuse near the jack in the yellow capsule. If the fuse is blown, be sure to replace it with only the same size AMP fuse.**

**MANUAL OPERATION OF FRONT JACK**

On the tongue jack, access to the jack post can be obtained by twisting the retaining ring and bulls-eye level counterclockwise. Insert the emergency jack wrench handle onto the jack post and crank the emergency hand crank wrench to raise or lower the jack as required.

**NOTICE**

**You do not have to remove or loosen screws on level to remove the level assembly. If the power-head is removed, crank can still be used to raise and lower jack.**

**MANUAL OPERATION OF REAR JACKS**

Rear jacks can be manually hand cranked from inside the trailer. Remove bedding and cushions on both sides of the trailer and remove the access panels. Locate the rear jack posts (jack covers not installed) and use the emergency jack wrench to raise or lower the rear jacks as required.

**BRAKING AND BURNISHING BRAKES**

The electric braking system will need to be burnished-in according to the manufacturer's instructions in order to obtain optimal performance. This will allow the brake shoes and magnets to slightly wear into the drum surfaces.

1. To burnish-in the brakes on your travel trailer, you will need to apply the brakes 20 to 30 times with approximately a 20 mile per hour decrease in speed between braking.
2. Allow ample time for the brakes to cool between applications.

For more information on Dexter axles and braking systems, contact Dexter or visit their website.

**PARKING ON A SLOPE**

Parking vehicles on an upgrade or downgrade is not recommended. If necessary, apply the brakes and have a passenger place wheel chocks behind the tires of your RV. When they are in place, slowly release brakes until chocks stop the unit. Apply the parking brake and place transmission in park position (place in first gear for manual shift vehicles).

**TOWING CHECKLIST ✓**

1. Close and secure all interior drawers and doors.
2. Close all windows and draw all blinds.
3. Secure the microwave plate.
4. Close the roof vents.
5. Close the backflow preventer valve.
6. Close and lock the storm door and the entry door.
7. Retract all stabilizer jacks.
8. Disconnect and store all power cords, cables, and hoses.
9. Shut off the propane tanks and secure the tank enclosure properly.
10. Secure the awning tightly in its casing and turn off the master power switch. Store the remote.
11. Secure the coupling to the hitch ball and lock the hitch pin.
12. Secure the 7-PIN connector plug to the tow vehicle.
13. Raise the steps up and into the storage position.
14. Check and secure the safety chains and safety breakaway cable.
15. Check all the operating lights and brake lights.
16. Secure any items in the storage basket or any attachments in the accessory receiver.
17. Check the lug nuts for the correct torque (110 ft/lbs).
18. Check the tires for the proper pressure.
19. Secure TV into folded position ensuring mounting catch is engaged to mounting pin.
20. Check dedicated breakaway battery.

**SETUP CHECKLIST ✓**

1. Pull or back into the campsite and ensure the trailer is level from side to side using leveling blocks. Chock tires and disconnect safety chains, 7-PIN cable, and breakaway switch.
2. Unlock the trailer coupler from the hitch ball by pushing the lever on the coupler forward.
3. Lower the front jack to raise the trailer off of the hitch ball.
4. Pull the tow vehicle forward so that you can level the trailer front to back using the front jack.
5. Lower rear jacks for stabilization only.
6. Pull out aluminum double step.
7. Make sure all appliances are in the off position.
8. Open propane tanks.
9. Plug in the trailer's 30 AMP shore power cord to the correct 30 AMP, 120-volt source. (In most cases there will be a 30 AMP breaker at the pedestal that must be turned on after hooking up.)
10. If there is a city water source, connect a potable hose to the spigot and the other end to the City Water Inlet at the rear, curbside. Be sure to connect the pressure regulator. Turn the water on.
11. Open the backflow preventer before using any water source in the trailer.

## ELECTRICAL

### OVERVIEW

The 30-amp electrical power supply provided for the Oliver is a dual system, operating with 120-volt AC and/or 12-volt DC. AC power is provided by either connecting the Oliver to an outside power source when parked, through use of your 30-amp power cord, adding an inverter option, or by use of a generator. A generator will supply AC power based on the generator's limitations.

120-volt functions in the Oliver include the air conditioner, convection/microwave, Suburban 3-way Self-Igniting Water Heater, TV, stove, and all GFCI protected 120-volt outlets. All other electrical functions in the Oliver are supplied with 12-volt DC power.

When it is not possible to access 120-volt power, the 12-volt battery system can supply the 12-volt system functions. The battery system is rechargeable by power converter/battery charger when the Oliver is attached to an outside 120-volt power source, by use of an external generator, or optional solar package.

### CONNECTING TO SHORE POWER

30-amp services are 120-volt limited to a total draw of 30 amps. The power cord from the RV is three-pronged. 30-amp service is the most common in the RV industry and is used widely in campgrounds through the U.S.

Even though any appliance in the RV can operate by itself, due to the 30-amp limitations, you may not be able to run certain groups of appliances at the same time (especially starting them at the same time). For instance, most air conditioners will draw up to 16 amps to start and then run continuously around 11 amps. A microwave or convection oven may pull as little as 11 amps or as much as 18. Doing both simultaneously may overload the circuit, causing a breaker to trip.

The following warning is located near the shore power receptacle(s) on the outside of your travel trailer:



### WARNING

This connection is for 110-125 Volt AC, 60 HZ, 30 Ampere supply. DO NOT exceed circuit rating. Exceeding the circuit rating can cause a fire and result in death or serious injury.

A 30-amp shore power cord is provided to attach the Oliver to a grounded power source. The electric utility service connection is located on the street side of the Oliver. The shore power cord is stored inside the basement storage or closet.

### NOTICE

We do not recommend using an extension cord to provide power to your trailer. If necessary, only use a 3-prong, 10 gauge, 30 AMP extension cord with a maximum length of 25 feet.

### CONNECTING TO A GENERATOR

Oliver recommends a generator with a 30-amp connector for optimal performance. You will need a 30-amp generator to operate your travel trailer as normal; however, you will need to use a neutral ground plug.

Running on an insufficient generator may not allow electrical components to run properly. Oliver recommends using a 3500-watt generator when an alternative power source is required.

### SURGE PROTECTOR

Your travel trailer is equipped with a Progressive Industries EMS-HW30C (electrical management system) surge protector. The surge protector is designed to protect the trailer's electrical system that is connected on the output side of the surge protector. The shore power connection, cord to the surge protector, and transfer switch (if equipped with optional second shore power connection) are not protected by the onboard surge protector.

### NOTICE

If you are concerned about protecting the shore power connection, cord to the surge protector, and transfer switch (if applicable) of the travel trailer, you will need to use an external 30 AMP surge protector that connects between the shore power cord and the power source (e.g., generator or power pole at campsite).

For operating instructions and troubleshooting, view the manufacturer's manual.

### BATTERY COMPARTMENT

The battery compartment is located on the street side of your Oliver. The marine-style latch can be locked using the small key found on your key ring. After opening the battery compartment box, you will notice a slide-out tray holding your batteries. Simply push the battery tray in to take pressure off the latch and pull the ball handles on the two side latches to unlatch the tray. Pull the tray out to inspect the batteries as needed.



The batteries have been strapped down to prevent them from shifting during transit. Periodically check the battery compartment to ensure the battery straps are tight, battery terminals are clean/corrosion free, and wire connections are tight.

### NOTICE

**NOT a dry storage compartment! Regular maintenance may be required to protect contents from deterioration.**

## BATTERY SAFETY

### WARNING

- › Always shield your eyes when working near batteries
- › Batteries can explode. Do not smoke or expose any battery to electric sparks or flame. Batteries generate hydrogen when charging or discharging. Hydrogen and air are a very explosive mixture. Do not short across the battery terminals. The sparks could ignite the gases.
- › **DO NOT** wear metal jewelry or a watch when working on a battery.
- › Before doing any work on electrical system, disconnect battery cable and 120-volt power cord.
- › **DO NOT** reconnect the cables until all work is completed: this will avoid the possibility of shorting or causing damage to electrical components or shock to the servicing person.
- › The battery electrolyte is corrosive, poisonous, and contains sulfuric acid. Avoid contact with skin, eyes, clothing, or any painted surface.

## 12-VOLT BATTERY SYSTEM

The heart of the 12-volt system are the batteries. Batteries are essentially storage devices for electrical energy.

Note: Differing loads affect the ampere-hour rating of a battery. In normal use, loads vary in both amperage and the length of time they are applied, so these figures should be considered a guide rather than an accurate representation.

Ampere-hour ratings vary depending on the size of the battery, the manufacturer, and the method used to calculate the rating. When ampere-hour ratings are known, they can be used to determine how many and what size batteries you need for your RV.

## STANDARD 12-VOLT BATTERIES

If your trailer is equipped with the standard batteries, you will find four wet cell batteries installed. The standard equipment batteries are RV or Marine Deep Cycle, Lead-Acid types. These batteries contain lead plates and liquid sulfuric acid electrolytes in sections called cells.

If wet cell batteries are installed on your trailer, they are maintenance free and do not require topping off. Wet cell batteries also release gas that requires venting, which you will find on the battery compartment door.

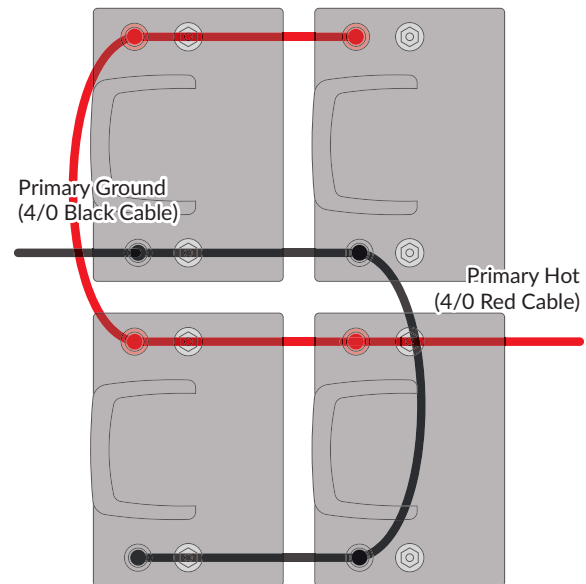

## SMART CHARGE WIZARD

*For standard 12-volt battery package only*

For operating instructions and troubleshooting, view the manufacturer's manual.

The smart charge wizard operates as the battery charger. It charges the batteries when it is connected to a 120-volt power source. If the battery is below its full charge, the charge wizard will begin operation at a rate that reflects the level of discharge.

The converter will supply "clean" power from input voltages that range from 105-130 VAC. At normal input voltages the full load capacity is available. At input voltages less than 105 VAC the converter may not supply full rated output capacity.

The power converter/charger is designed to provide reliable filtered DC power to all recreational vehicle 12-volt lighting and appliance CIRCUITS. The converter also provides safe and rapid recharging of the RV batteries. Built-In features such as electronic current limiting, reverse battery protection, high voltage protection, low voltage operation, and over temperature shut down ensure long term reliability.

The built-in charge wizard is a microprocessor-controlled system that constantly monitors the battery voltage and ensures rapid yet safe recharge. The charge wizard can select one of three charging voltages and one of four operating modes depending on the condition and use of the battery.

**Boost Mode:** If the voltage drops below a preset level the output voltage is increased to approximately 14.4 VDC to rapidly recharge the battery.

**Normal Mode:** Output voltage is set at approximately 13.6 VDC

**Storage Mode:** If there is no significant battery usage for 30 hours the output voltage reduces to 13.2 VDC for minimal water usage. In storage mode, the output voltage increases to 14.4 VDC for approximately 15 minutes every 21 hours to help prevent sulfation of the battery plates.

## INVERTER / CHARGER

*(For AGM and Lithium battery packages only)*

For operating instructions and troubleshooting, view the manufacturer's manual.

The optional inverter/charger is a combination of an inverter, battery charger and transfer switch in one complete system. When AC power is available, the inverter/charger recharges the batteries. It also allows surplus AC

power to pass through and power downstream AC loads, such as a television, microwave, or air conditioner. When AC power is disconnected, the unit can invert DC battery power into AC electricity. The inverter/charger will charge batteries in a sequence known as three-stage charging.

The charging voltage delivered to the battery depends on the battery's type, temperature & state of charge. The three automatic charge stages are Boost, Absorption & Float.

**Bulk Stage:** the first stage in the charging process provides the batteries with a controlled, constant current. Once the battery voltage rises to the absorption voltage threshold, the charger switches to the absorption stage.

**Absorption Stage:** during the absorption stage, the inverter/charger begins operating in a constant voltage mode and the current falls gradually as the amp hours are returned to the battery.

**Float Stage:** maintains the batteries slightly above shelf discharge voltage. The charger automatically switches to the float stage after the batteries have received a bulk and absorption charge.

## INVERTER / CHARGER SETUP

Your optional equipment will be setup before delivery and should not require changes.

See the settings chart for each model & battery type:

SETTING #	SETTING	6V AGM 440 AH	12V LITHIUM 390 AH	12V LITHIUM 640 AH
01	INVERTER IGNITION CONTROL	OFF	OFF	OFF
02	LBCO VOLTAGE	10.5V	11.5V	11.5V
03	LBCO SHUTDOWN DELAY TIMER	300	10	10
04	LBCO RECOVERY VOLTAGE	13.1V	13.1V	13.1V
05	POWER SAVE TIME	OFF	OFF	OFF
06	POWER SAVE MODE (LOAD SENSING)	dls	dls	dls
07	OUTPUT FREQUENCY	60	60	60
08	OUTPUT VOLTAGE	120V	120V	120V
09	INVERTER OUTPUT POWER LIMIT	2.0	3.0	3.0
10	INVERTER OUTPUT LIMIT TIMER	300	300	300
11	TRANSFER MODE	APL	APL	APL
12	UTILITY AC UNDER VOLTAGE	90	90	90
13	INVERTER SHUTDOWN RECOVERY	nAt	nAt	nAt
14	AUDIBLE ALARM	b0n	b0n	b0n
20	BATTERY TYPE	AGM	LFP (LIFEPO)	LFP (LIFEPO)
21	BATTERY TEMPERATURE	HOT	HOT	HOT
22	CUSTOM ABSORPTION	—	—	—
23	CUSTOM FLOAT VOLTAGE	—	—	—
24	CHARGER CURRENT	60	150	150
26	CHARGE IGNITION CONTROL	OFF	OFF	OFF
27	EQUALIZE CHARGING	dls	dls	dls
28	AC INPUT BREAKER	25	25	25

**INVERTER TRANSITION**

The inverter automatically detects when shore power is present and when it becomes unavailable or drops to less than 106 VAC. The inverter will transition from grid mode to battery mode in less than 20 milliseconds and starts drawing from the batteries. When operating on battery mode and shore power becomes available, the inverter will begin a 20 second countdown to verify stability of the shore power. If shore power remains stable, the inverter will switch to shore power mode.

 **WARNING**

Your Oliver camper is equipped with an onboard surge protector that controls incoming shore power and shuts it off when the voltage drops below 104V or goes above 132V.

Leaving the inverter on to transition into battery mode automatically may result in battery discharge.

NOTE: The Xantrex Remote Panel Display; green Status LED, will light up to show which mode the inverter is in.

**MAINTENANCE**

Periodically you should:

- › With all sources of power off, clean the exterior of the unit with a damp cloth to prevent the accumulation of dust and dirt.
- › Ensure that the DC cables are secure and fasteners are tight.
- › Make sure the ventilation openings are not clogged.

Note: The information provided in this manual is a basic overview. For the full Xantrex Pro owner's manual please see the Options Manual.

**SOLAR PACKAGE**

*(Optional Equipment)*

For operating instructions and troubleshooting, view the manufacturer's manual.

The optional solar system is a 12-volt system that provides an off-grid ability to recharge your batteries when shore power is not available. It is important to understand that the solar does not charge as quickly as a 120-volt shore connection. If the batteries are severely depleted you may need to connect to a generator or 30 AMP shore connection.

When you are off-grid, you should check periodically on the battery voltage or state of charge.

**SOLAR DISCONNECT SWITCH**

To isolate the solar panels from the battery bank, use the disconnect switch located in the upper cabinet to the left of the stereo on the street-side of the trailer.



**AGM BATTERIES** *(Optional Equipment)*

For operating instructions and troubleshooting, view the manufacturer's manual.

The 6-volt AGM Battery is specifically designed for deep-cycle applications. The Elite II model has four 6-volt batteries wired in series & parallel to provide 12-volt power. AGM batteries can effectively deliver 50% of their total amp hour capacity. The AGM batteries on the Elite II model delivers a usable 220 amp hours.

**6-VOLT AGM BATTERY CONFIGURATION**

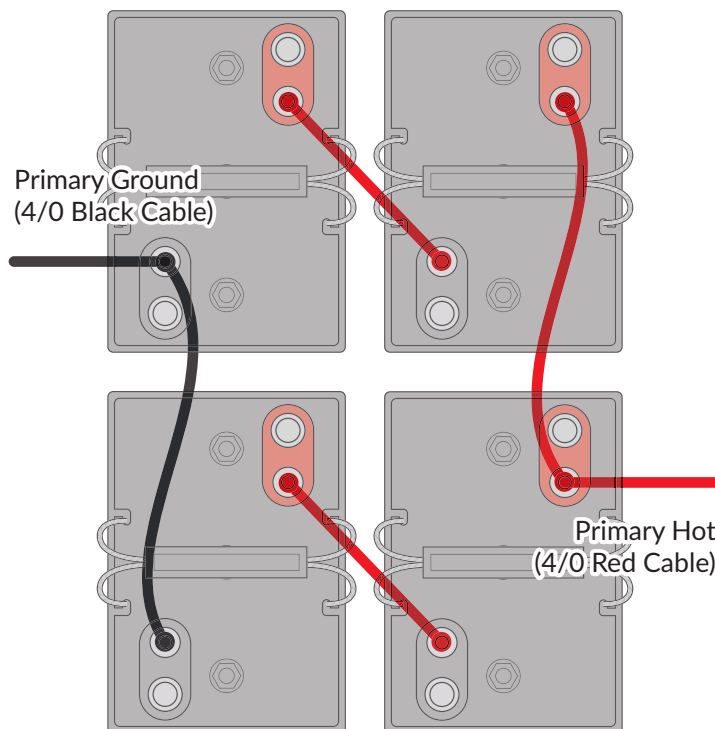

**LITHIUM BATTERIES** (Optional Equipment)

Lithium batteries feature a built-in Battery Management System (BMS). The BMS features different protection modes including, over and under voltage, over and under temperature, over current, short circuit and more. The Bluetooth mobile app communicates directly with the battery to allow you to monitor temperature and charge status. Lithium batteries can effectively deliver 90% capacity at 12-volts and the remaining 10% capacity below 12-volts. Once the battery reaches the last 10% capacity they will shut down, however the user can turn the batteries back on and utilize the remaining 10% for emergency situations.

**NOTICE**

Due to the high ampere draw of the inverter while charging the batteries, **DO NOT** use a 30 Amp Adapter into a 15 Amp outlet to charge lithium batteries.

**130 AH LITHIUM BATTERIES** (Optional Equipment)

For operating instructions and troubleshooting, view the manufacturer's manual.

When a charge cycle is desired on the batteries and the temperature outside the trailer is above freezing then no action is needed. If the temperature outside the trailer is below freezing, the Lithium batteries will need to be warmed before they can be charged. You will need to access the battery compartment and switch on the battery thermal blanket.

The switch will be an in-line on/off switch located on the battery harness on top of the batteries. Once the heater has been turned on be sure to close the battery compartment door. When the battery core temperature is above freezing, the battery will begin accepting a charge.

NOTE: The colder the core is, the longer it will take to warm up to above freezing. The battery's thermal blanket is thermostatically controlled between 35° Fahrenheit and 45° Fahrenheit. If a single charge is desired, switch off the battery's thermal blanket when charging is complete. If the travel trailer is being used in a cold environment, leave the thermal blanket switch on for the duration of the trip and switch it off when the trip is over.

**12-VOLT LITHIUM BATTERY CONFIGURATION**

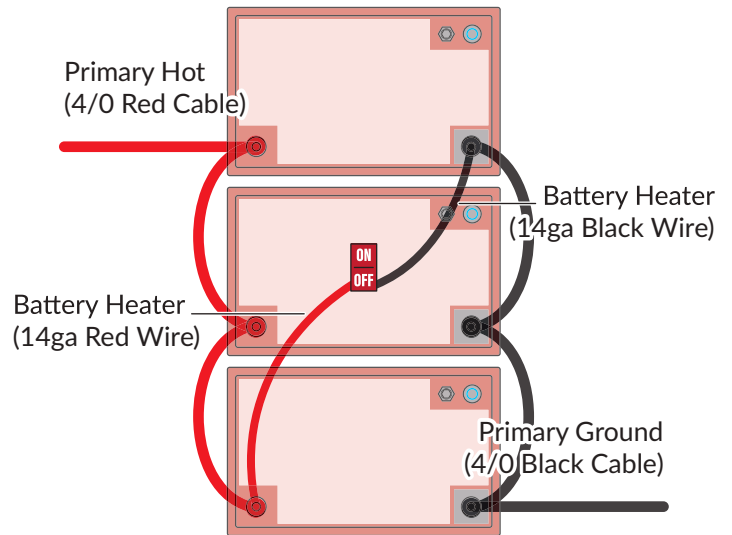

**130 AH LITHIUM BATTERIES PROPER RESTART**

If the inverter is OFF, drained or has entered Low Battery Cut Off (LBCO) and any or all of the batteries are OFF (no LED light on battery), you must properly restart/reboot the system to avoid damaging the internal Battery Management System (BMS). See our video on YouTube.

**The following procedure should be followed to Reboot/Restart:**

1. Ensure that the inverter is turned OFF.
2. Under the street side bed access panel, switch the inverter disconnect to the OFF position.  
 Note: This will cause a communication issue for the inverter remote display and requires a proper restart sequence to ensure proper communication between the inverter and remote display. (Error 20)
3. Turn all batteries ON.
4. Switch inverter disconnect to the ON position.
5. Turn the inverter ON at the inverter.
6. Verify communication software has loaded.  
 Note: Press the Up/Battery Button to scroll through.
7. Turn the inverter OFF at the inverter.
8. Turn the inverter remote display ON.

**320 AH LITHIUM BATTERIES (OPTIONAL EQUIPMENT)**

For operating instructions and troubleshooting, view the manufacturer's manual.

The 320 AH lithium battery has a built-in heating system and does not require a separate heat mat. When charging is required and temperatures are below freezing the built-in BMS will automatically heat the internal temperature of the battery so that it charges properly.

12-VOLT LITHIUM BATTERY CONFIGURATION

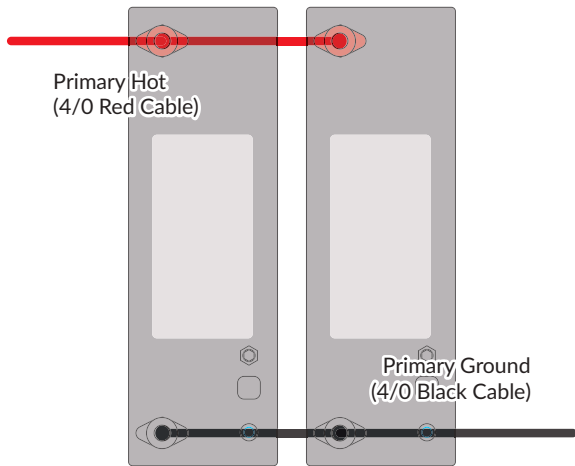

CIRCUIT BREAKERS

The 120-volt system is protected by circuit breakers in the AC panel located under the left front dinette seat, which automatically shuts the circuit off if the circuit load is too heavy or a short circuit occurs. If a circuit breaker has been tripped, do not reset the breaker until the cause of the problem is identified and corrected. Verify that the 120-volt GFCI outlet under the dinette is not tripped. In the event the outlet is tripped, it has to be reset by pushing the “reset” button on the 120-volt outlet.

**NOTICE**

GFCI is only energized when AC power is present.

LITHIUM BATTERIES STORAGE PROCEDURE

Storing your lithium batteries at the correct specifications is important as it keeps the battery in the healthiest state possible for the fastest deployment when needed.

See the manufacturers manual for proper lithium battery storage procedures.

120V PANEL – STANDARD CONFIGURATION

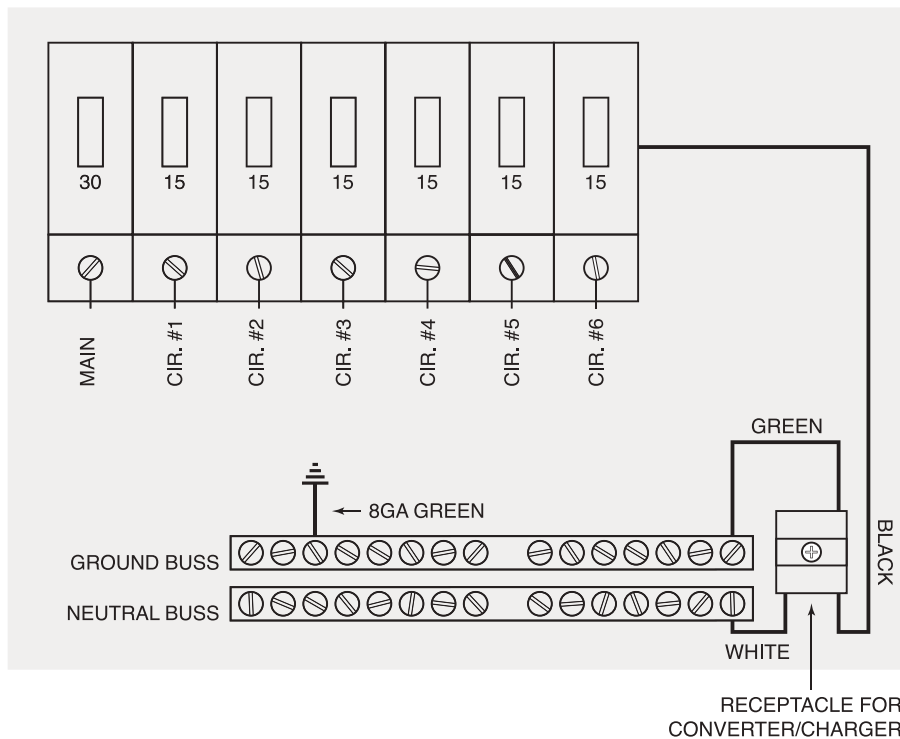

120V BREAKER DESCRIPTIONS

MAIN	—	30 AMP
CIR. #1	WATER HEATER	15 AMP
CIR. #2	RECEPTACLES	15 AMP
CIR. #3	MICROWAVE RECEPTACLE	15 AMP
CIR. #4	AIR CONDITIONER	15 AMP*
CIR. #5	CHARGER	15 AMP
CIR. #6	STOVE	15 AMP

\*Circuit will be protected by a 20 amp breaker when equipped with Truma A/C option.



120V PANEL – PRO 2,000W INVERTER CONFIGURATION

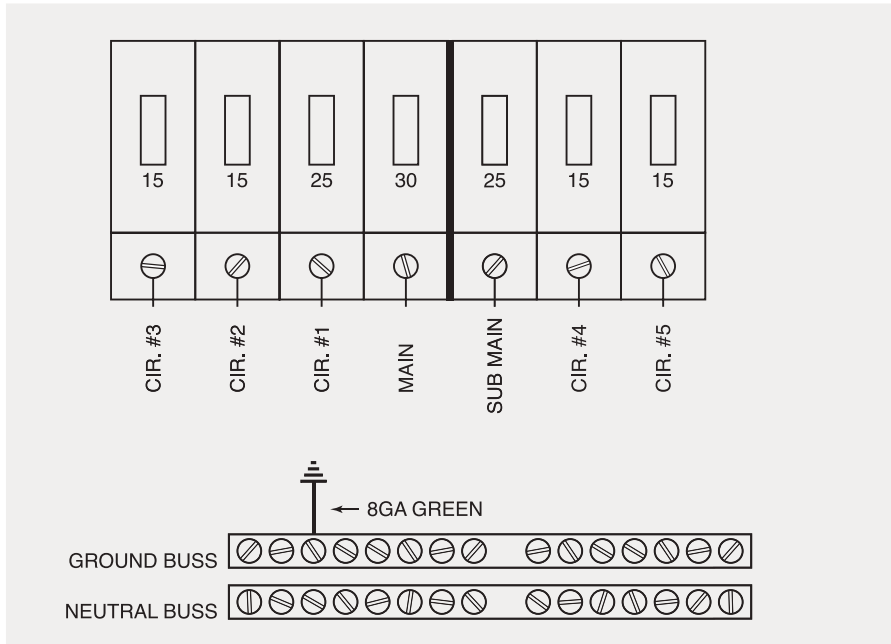

120V BREAKER DESCRIPTIONS

CIR. #3	STOVE	15 AMP
CIR. #2	AIR CONDITIONER	15 AMP*
CIR. #1	INVERTER	25 AMP
MAIN	–	30 AMP
SUB-MAIN		25 AMP
CIR. #4	RECEPTACLES	15 AMP
CIR. #5	MICROWAVE RECEPTACLE	15 AMP

\*Circuit will be protected by a 20 amp breaker when equipped with Truma A/C option.

120V PANEL – PRO 3,000W INVERTER CONFIGURATION

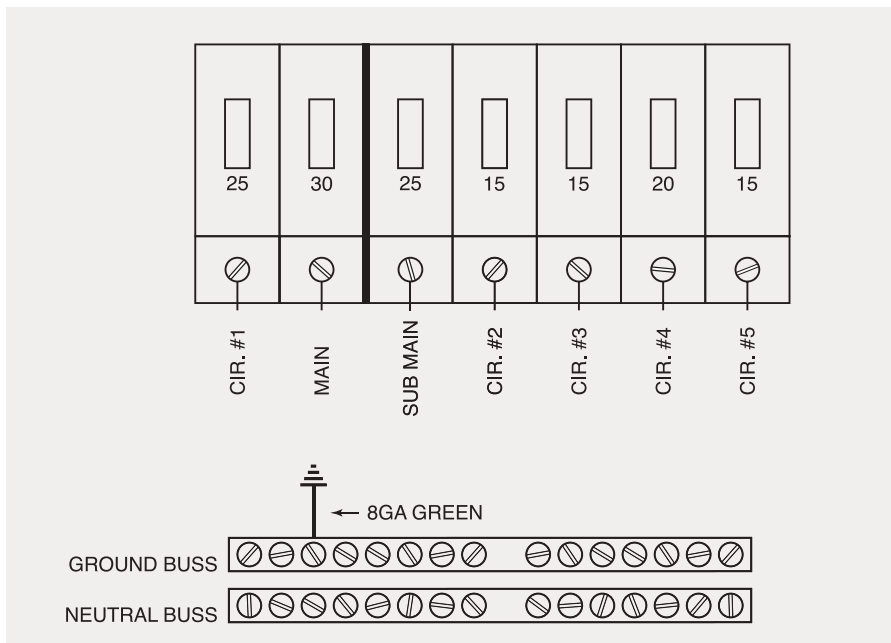

120V BREAKER DESCRIPTIONS

CIR. #1	INVERTER	25 AMP
MAIN	–	30 AMP
SUB-MAIN	INVERTER SUBPANEL	25 AMP
CIR. #2	RECEPTACLES	15 AMP
CIR. #3	MICROWAVE RECEPTACLE	15 AMP
CIR. #4	AIR CONDITIONER	20 AMP
CIR. #5	STOVE	15 AMP

### 12V FUSES

A 12-volt DC distribution panel is located under the dinette. The panel contains fuses that protect the 12-volt circuitry. If any circuit is loaded beyond the capacity of its fuse, the fuse will blow. If a fuse is blown, replace it with a fuse of the same amp rating. Do not replace it with a larger fuse than indicated.

If the fuse continues to blow, contact your nearest Oliver dealer or a qualified RV service center for assistance. It is a good idea to keep additional fuses on hand in your travel trailer. Replacement fuses are available at service stations, hardware stores, or automotive supply stores.

### 12V PANEL CONFIGURATION

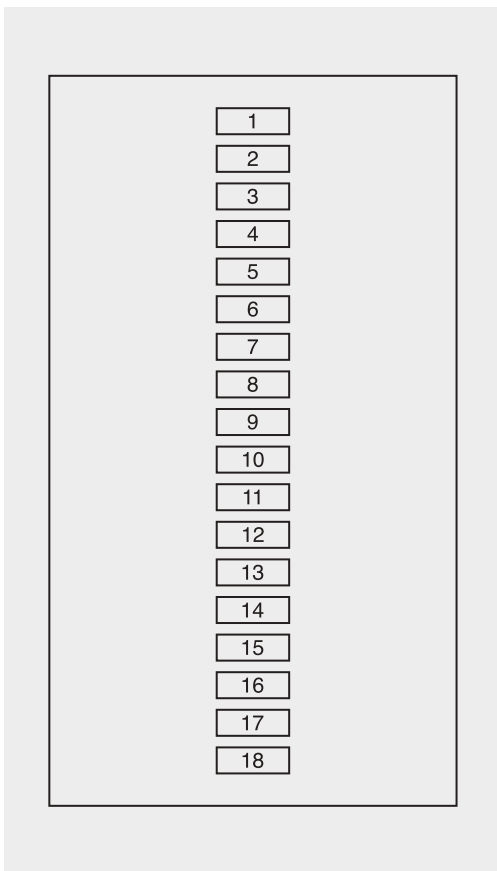

12V FUSE DESCRIPTIONS		
1	REFRIGERATOR	15 AMP
2	ELECTRONICS*	15 AMP
3	WATER PUMP	15 AMP
4	FURNACE	10 AMP
5	LIGHT MAIN	10 AMP
6	FANS	15 AMP
7	WATER HEATER	7.5 AMP
8	12V RECEPTACLE / USB**	15 AMP
9	12V RECEPTACLE / USB***	15 AMP †
10	CB AWNING (OPTIONAL)	10 AMP †
11	ST AWNING (OPTIONAL)	10 AMP †
12	CABIN / CABINET LIGHTS	5 AMP †
13	ELECTRIC BLADE VALVE	5 AMP
14	OPEN	
15	OPEN	
16	OPEN	
17	OPEN	
18	OPEN	

\* Back-up Camera, Tank Monitor, Speaker.

\*\* 12V Socket/USB at Dinette, 12V socket/USB under attic.

\*\*\* 12V Socket in Attic, 12V Socket/USB in Kitchen.

† ATC Style Type 2 Breakers.

## ADDITIONAL BREAKERS & FUSES

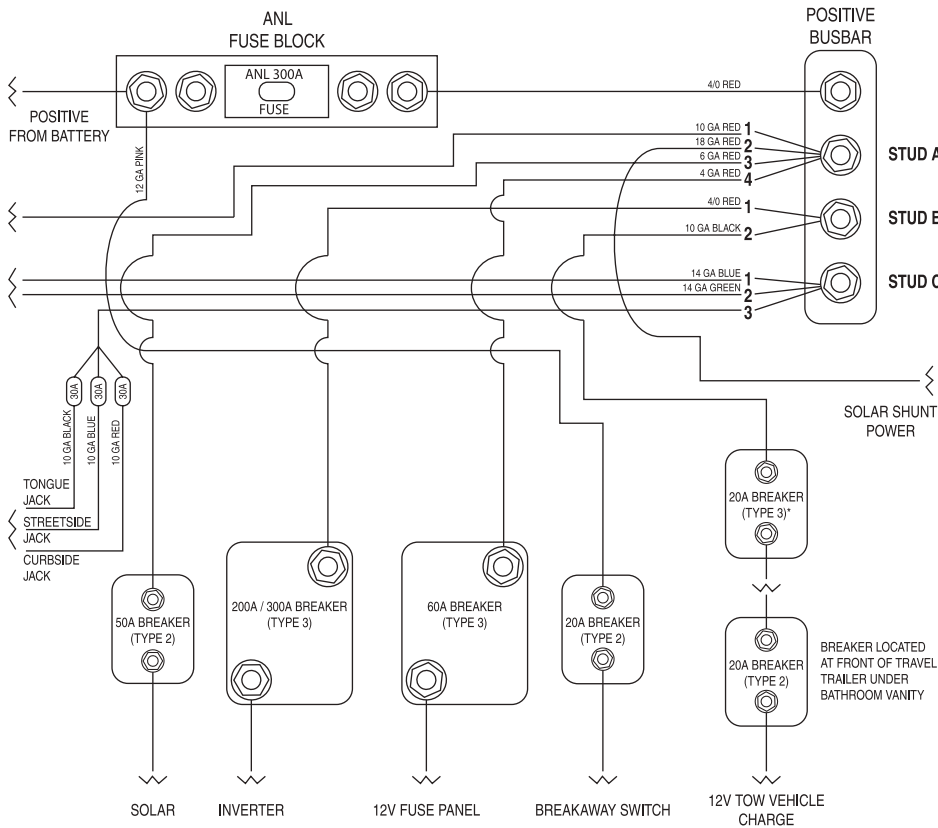

### BUSBAR CONNECTIONS & ADDITIONAL FUSING / BREAKERING INFO.

STUD A		
1	EXTERIOR SOLAR PORT	15 AMP (ATC FUSE)
2	SOLAR SHUNT POWER	1 AMP (SLOW BLOW)
3	SOLAR	50 AMP (TYPE 2 BREAKER)
4	DC FUSE PANEL	60 AMP (TYPE 3 BREAKER)
STUD B		
1	INVERTER CHARGER	200 AMP / 300 AMP (TYPE 3 BREAKER)
2	12V TOW VEHICLE CHARGE	20 AMP (TYPE 3 BREAKER)*
STUD C		
1	CO/LP DETECTOR POWER	1 AMP (ATC FUSE)
2	COMPOSTING TOILET POWER	2 AMP (GLASS FUSE)
3	ELECTRIC JACKS	30 AMP (SLOW BLOW)

*\*Dealer Option*

**\*\*Breaker not installed when travel trailer is equipped with lithium batteries**

SOLAR PANEL FUSE (ON ROOF OF CAMPER)

## OUTLETS AND CHARGING STATIONS

All of the 120-volt outlets on the receptacle circuit in the Oliver are GFCI protected. You will find the main GFCI outlet below the right dinette seat.

Check the operation of your GFCI outlets monthly by depressing the test button on the main GFCI outlet, then re-energize the circuit by depressing the reset button.

If you find that your 120-volt outlets are not working on your trailer, troubleshoot by checking the following:

- › Whether the main GFCI outlet under the dinette is tripped.
- › Whether the breaker for the receptacle circuit is tripped.
- › Whether the main breaker for the AC panel is tripped.
- › Ensure that 120-volt power is present and there are no errors on the surge protector.

### NOTICE

**GFCI is only energized when AC power is present.**

If any of the three are tripped, reset them. If they continue to trip, contact your nearest Oliver dealer or a qualified RV service center for assistance.

When it's time to charge your mobile phones or tablets, you will find charging stations located throughout the interior of your trailer. Each charging station is equipped with one 12-volt plug-in and two USB plug-ins.

**LIGHTING AND SWITCHES**

The main light switches are located on the switch panel just inside the door.

MASTER LIGHTS switch allows you to turn on or off power to all light switches.

PORCH LIGHTS (CURB/STREET) switches will turn on and off the LED porch lights on the curbside and street side of your travel trailer.

OUTSIDE COURTESY LIGHTS switch will turn on and off all of the outside courtesy lights located on both sides of your Ollie near the bottom of the shell.

MAIN CABIN LIGHTS switch controls the main LED lights that are located on the interior roof of the trailer.

CLOSET LIGHTS switch controls the LED light in the closet.

CURB AWNING switch is the master power button for the powered awning on the curbside of the trailer.

STREET AWNING switch is the master power button if the trailer is equipped with the optional powered awning on the street side of the trailer.

REAR CAMERA switch provides power to the optional rear backup camera.

CABINET LIGHTS switch controls the LED lights in the upper cabinets.

DINETTE LIGHTS are switch LED lights. The MASTER LIGHTS switch provides the power needed for each light.

REAR LEFT LIGHTS are switch LED lights. The Master Lights switch provides the power needed for each light.

REAR RIGHT LIGHTS are switch LED lights. The MASTER LIGHTS switch provides the power needed for each light.

READING LIGHTS are push switch ON/OFF lights.

BATHROOM LIGHTS switch is located on the bottom of the upper cabinet above the toilet on Legacy Elite II models.

WATER PUMP switch is the master switch to provide power to the water pump. There is one in the main cabin on the SEE LEVEL monitor and one in the bathroom.

INSIDE COURTESY LIGHTS switch is located under the pantry. The switch controls the LED lights near the floor throughout the interior of the trailer.

WATER HEATER switch is the master switch to provide power to light the burner on the water heater.

If your exterior lights are not working but you have power to trailer, check the fuses in the fuse panel located in the rear upper cabinet and replace if necessary

**MAIN ENTRY SWITCH PLATE**

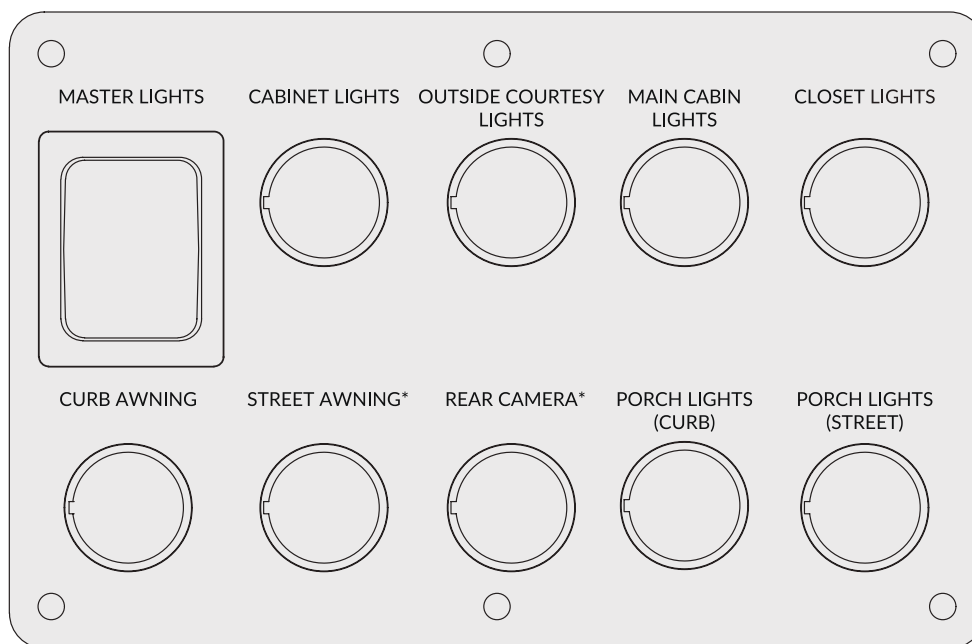

\*Switch will be plugged if not equipped with optional components.

## PLUMBING

### OVERVIEW

Oliver's plumbing can be divided into two separate systems. The freshwater system consists of those items which are used to deliver water for your use. The wastewater system includes the drains and tanks that store and remove water that has been used.

The plumbing system has the dual ability to be self-contained with onboard storage, complemented by a digital holding tank monitoring system, or to use facilities providing an external pressurized source. In either case, the components of the system operate like those in your home.

Components of the plumbing system consist of strong, lightweight, corrosion-resistant materials. By following the instructions outlined here, you can expect efficient operation with minimum maintenance. Freshwater is provided from an external pressurized source or from the freshwater storage tank. These connections on the Oliver are located at the rear, bottom driver side corner of the trailer. Most of the important plumbing components and valves are found under the curbside seating access panels. These components are referenced throughout the Plumbing section of this manual. Below are diagrams of the Normal Valve, Fresh Tank Fill Valve, and Winterization/Decalcification Valve Configurations.

### PLUMBING SYSTEM – CURBSIDE ACCESS PANEL

Most of the important plumbing components and valves are found under the curbside seating access panels. These components are referenced throughout the Plumbing section of this manual.

The following are diagrams of the Normal Valve, Fresh Tank Fill Valve, and Winterization/Decalcification Valve Configurations.

#### Normal Valve Configuration

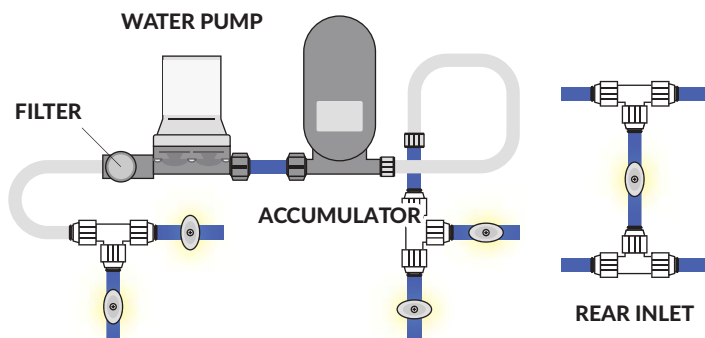

#### Fresh Tank Fill (Non-Pressurized)

Drawing water from rear inlet to fill fresh tank

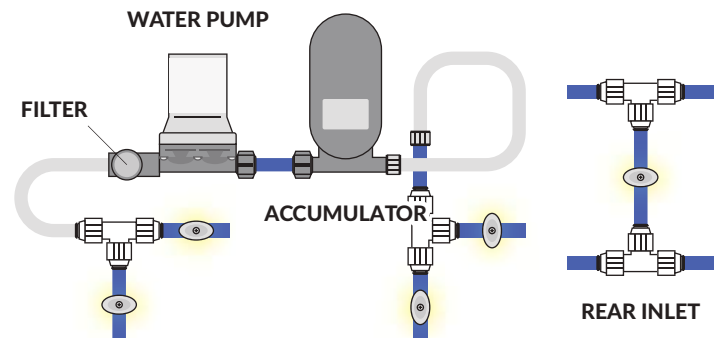

#### Winterization/Decalcification Valve Configuration

Drawing non-toxic RV anti-freeze from rear inlet directly to faucets and toilet

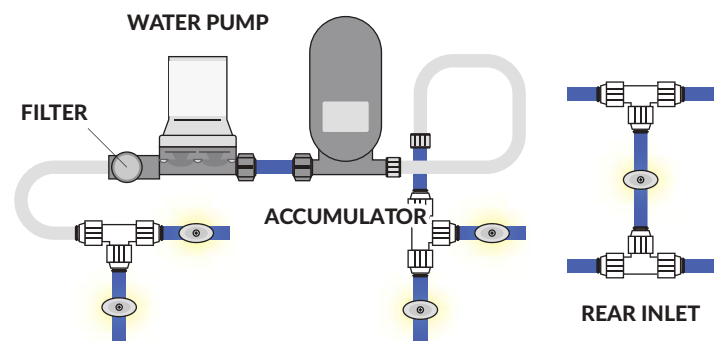

### PLUMBING SYSTEM COMPONENTS & VALVES

Under front curbside seating access panel

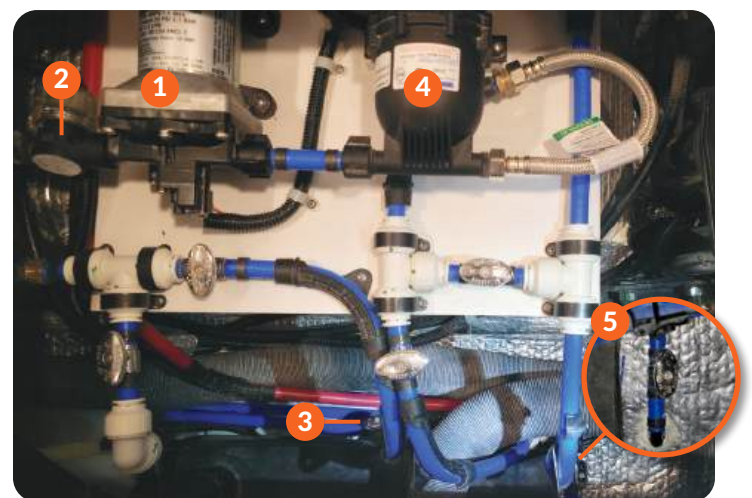

1. Water Pump
2. Water Pump Filter
3. Factory Inspection Valve (Always leave open)
4. Accumulator
5. Freshwater Drain Valve



## WATER PUMP & ACCUMULATOR

For operating instructions and troubleshooting, view the manufacturer's manual.

Under the curbside bed access panel, you will find the Water Pump, Accumulator, and other valves. When using water from the freshwater tank, the system must be pressurized. The self-priming 12-volt DC water pump is provided to handle this function. The accumulator tank provides additional water storage to assist the pump in meeting the total demands of the system and helps minimize pulsation at the faucets.

As previously mentioned, the Water Pump can be used along with the Rear Water Inlet to push water from a portable potable water container into the Freshwater Tank. The pump can also be used during Winterization, Sanitization, and Decalcification.

### Water Pump Switch Locations:

- › A "PUMP" on/off switch is located on the SeeLevel II monitor located in the main cabin. See the SeeLevel II Tank Monitor diagram later in this section.
- › Another switch is in the bathroom above the towel bar in the vanity.

### When Initially Starting Up the Self-Contained Water System:

1. Make sure the fresh water tank is filled with water.
2. Place the pump control switch in the ON position.
3. Allow time for the pump to fill the hot water tank and fully pressurize the system (approx. 2 minutes).

The system is now ready for use.

### WARNING

Running the water pump for more than 2 minutes may cause pump failure.

### NOTICE

The self-contained water system is a demand system. This means that the water pump will run whenever there is a need for water.

## TANK MONITORING

For operating instructions and troubleshooting, view the manufacturer's manual.

The tank monitor consists of a display unit that mounts on an upper cabinet inside the travel trailer, and sending units that stick to the side of the holding tank. The tank monitor will monitor the battery voltage, the freshwater tank, grey water tank, and black tank.

NOTE: The main water "PUMP" switch is located on the SeeLevel II Tank Monitor panel. The green indicator light will illuminate when the water pump is turned on.

## CITY WATER INLET

The city water connection is located on the lower rear curbside of the trailer. Water provided from outside the Oliver is pressurized by the system from which it is delivered. When you connect your Oliver to an outside source, the freshwater tank and the water pump are kept separate from the remainder of the system by an in-line check valve.

### How to attach your trailer to a city water connection:

1. Remove the cap from the city water inlet on the lower rear curbside of the Oliver.
2. Attach a potable water hose to the outside source of water. An external water filter is recommended.
3. Connect the other end of the hose to the Oliver city water inlet. Be sure to use a pressure regulator (included at delivery) with a maximum 55 PSI.

### WARNING

Failure to use a pressure regulator may damage the internal water system.

4. Turn on the outside source of water. Open the various faucets gradually to clear the air from the lines. Close the faucets when the water flows freely.

NOTE: May need to turn on the hot water side of the faucet to remove any air trapped in the water heater.

5. Be sure the water heater is full of water before turning on the hot water heater

### NOTICE

DO NOT turn the water pump on when using water from an external pressurized supply. This could result in damage to the water pump.

## FRESHWATER INLET

The freshwater connection is located on the lower rear street side of the trailer. The freshwater inlet allows you to pre-fill your on board water tank when planning to camp somewhere without an outside water source. The tank is filled through a standard pressurized water hose connection located at the rear area next to the city water inlet. The standard capacity of the freshwater tank is 30 gallons.

To fill the freshwater tank from pressurized water:

1. Remove the cap from the freshwater inlet.
2. Attach a freshwater hose to an outside water source.
3. Attach the other end to the Oliver freshwater inlet.
4. Turn on the water source; fill until water starts to run from the freshwater overflow, which is located on the opposite side, between the aluminum steps and the curbside tire.
5. When the tank is filled, turn off and disconnect the outside water hose and re-install the water cap.

### NOTICE

- › If you notice water leaking under the camper you may need to close the fresh tank drain valve.
- › Always fill the tank with clean water from a known safe source. Make sure to cap the water inlet when the tank is filled. Always fill the system with a hose that you know is clean and is used only for this purpose. Water from tanks is not intended for consumption.

## DRAINING THE FRESHWATER TANK

Under the curbside bed access panel below the water pump, you will see a standard T-valve (refer to images on page 31). Opening this valve allows you to drain the freshwater tank before traveling, when winterizing, or as otherwise needed. The water will be released below the trailer near the rear bumper. Do not forget to close the valve after emptying the freshwater tank.

### NOTICE

**When trying to drain the entire on-board freshwater system, make sure to open faucets and remove the water heater drain plug. This will Equalize the air pressure and allow free water flow. It may be necessary to raise the front stabilizing jack to allow gravity to help drain the freshwater tank.**

## REAR WATER INLET

The rear water inlet is located on the lower right, rear of trailer. This inlet serves multiple purposes using the Water Pump to pull water into the freshwater tank or plumbing lines.



### WARNING

**The sanitization and decalcification process should NEVER be done together. Mixing vinegar and bleach can cause a lethal toxic gas!**

### The rear water inlet is used for:

- › Filling the freshwater tank from a potable water container using the onboard water pump when city water is not available.
- › Pumping non-toxic RV antifreeze into the water lines when winterizing.
- › Sanitization of the plumbing system.
- › Decalcification the plumbing system

### To fill the freshwater tank from a portable potable water container (non-pressurized):

1. Remove the cap from the curbside rear water inlet.
2. Attach a cut-off potable hose to the curbside rear water inlet that is 2' max in length.
3. Insert the other end into the potable water container.
4. Go inside and change the water pump valve configuration to the non-pressurized fresh tank fill mode under the curbside access panel. (See valve configurations).
5. Turn the main water pump switch on until all water is pumped from the portable water container into the freshwater tank.
6. When the tank is filled, turn off the water pump, turn the water pump valves back to the normal configuration, disconnect the outside water hose and re-install the inlet cap.

## WATER HEATER

For operating instructions and troubleshooting, view the manufacturer's manual.

## FAUCETS & SHOWER

### BATHROOM FAUCET

The bathroom faucet is installed with a flexible hose for showering and for cleaning the shower. To turn on the bathroom faucet, lift the handle up to open the flow of water. Turn the lever counter-clockwise to adjust the water to the desired temperature.

To use the bathroom faucet as a shower, pull the head from the faucet to extend the flexible hose and place it into the shower mount on the upper right wall. You can change the water flow from spray to stream by toggling the switch on the back of the faucet head.

### CAUTION

The bathroom faucet hose should only be pulled out to the shower head mount. Pulling it out farther might result in a kinked or damaged hose.

#### KITCHEN FAUCET

The kitchen faucet features a pull-down spout and two-way spray head. To turn on the kitchen faucet, pull the handle toward you to open the flow of water. Push the handle right or left to adjust the water to the desired temperature. You can change the water flow from spray to stream by toggling the switch on the back of the faucet head.

#### OUTSIDE WASH STATION

The outside wash station is located in the basement storage compartment on the rear street side of the trailer. Pull the white cover down to access the faucet and controls. Turn the hot (red) and cold (blue) knobs as needed to the desired temperature. The faucet is connected to a flexible hose that stores inside the casing. Push the lever on the back of the shower head to open the flow of water. The flow of water can be locked open or closed by pushing or pulling the lever as needed.

### CAUTION

Be sure to close hot and cold knobs on the outside wash station after use. Failure to do so can cause back feeding of water into plumbing lines.

#### SHOWER CARE

From time to time you will want to remove soap film from the shower wall. Use any mild household foam cleaner. Never use harsh chemicals or abrasives on the shower walls or shower base.

After taking your shower, leave the bath door open to allow the humidity and moist air to escape. Also, leave the bath door open when the unit is not in use. This allows circulation of air and prevents mildew.

#### TOILET

Your Oliver Travel Trailer is equipped with either a standard porcelain toilet or an optional composting toilet.

For operating instructions and troubleshooting, view the manufacturer's manual

#### BACK-FLOW PREVENTER

The black T-handle in the bathroom near the bottom of the wall is connected to a blade valve that controls the flow of used water from your shower pan and sink to the gray tank.

### NOTICE

It is important to open this valve during camping and close the valve before traveling. This will prevent any water left in the gray tank from back-flowing into the shower pan while driving.

#### DUMPING WASTE

##### WASTEWATER SYSTEM

The wastewater system in your Oliver can be described as two separate systems; a gray water system that consists of the drain lines and a holding tank for wastewater from the sinks and shower and a black water system, which includes the holding tank and drain for toilet wastes. Each system is self-contained and allows disposal of the wastewater at designated dump stations.

The gray water system has drain traps. Both tanks are vented to equalize air pressure and disperse odors caused by drain water and waste. The traps may empty during transit and allow the odors of the gray water tank to come into the coach. Residue in the drain water lines also can produce odors. To combat gray water holding tank odor, an approved deodorizing agent should be used. An agent that dissolves grease and fats and contains a detergent that will help keep tank and drain lines clean and free-flowing.

##### HOLDING TANKS

Your trailer's waste holding tanks hold 30 gallons in the gray tank and 15 gallons in the black tank. Each tank should be emptied often at a dump station designated for this purpose. Most national, state, and private campgrounds have dumping facilities. Many service stations, particularly along interstate highways, also have these facilities and are listed dumping station locations across the nation.



### To Empty the Holding Tanks:

1. Remove the two pins from both sides of the aluminum bumper, and pull the flexible sewer hose out.
2. Remove the end cap from the drain line and install the flexible drain hose. Position the flexible drain hose over the dump station inlet. Make sure the drain line is securely attached. Both drain termination switches are located in the basement storage compartment.
3. Open backflow preventer in the bathroom to prevent the gray water tank from air locking.
4. Drain the black water tank first by switching the termination valve to open. Make sure to allow sufficient time for the tank to completely drain and then rinse the tank with several gallons of water by depressing the toilet's flush pedal. Close the toilet's flush lever and fill the toilet with water, then flush. This creates an additional force to clean the tank more completely.
5. Drain the gray water tank by switching the termination valve to open. Draining the gray water tank last, with its soapy water, helps to further rinse the drain and flexible drain hose.
6. When tanks are emptied, close the termination valves by switching both termination valves to closed. Ensure the backflow preventer is closed before traveling.
7. Remove flexible drain hose from the dump station inlet, using the shower hose, rinse off the flexible drain line if needed, cap it and replace it in the storage behind the rear bumper. Secure the bumper and cap the dump station inlet.

### WASTE HANDLING

The following guidelines will help to ensure trouble-free operation:

- › Never put anything in the black water tank other than toilet paper, especially for RV systems
- › Always use cleaners made for the RV industry in the black water system.
- › Do not put automotive antifreeze, household toilet cleaners, drain cleaners, or any solid material into the wastewater system.
- › Always keep the drain cap in place and termination valves closed when not dumping your tanks
- › After every third time the holding tanks are emptied, fill and flush both tanks with clean, fresh water a couple of times to keep them clean and clear.

If connecting to a campsite sewer inlet, DO NOT open termination valves until tanks are  $\frac{3}{4}$  full. DO NOT keep the black water valve open when parked. Solid wastes are not flushed directly into the sewer system. Only liquid waste is drained. Water must accumulate and chemicals in the tank need time to break down solids before they can be released. If draining the gray water tank directly into sewer inlet while parked, make sure to close the termination valve for a period of time before leaving. This will allow some water to accumulate in the tank to use for flushing the drain line and flexible hose.

### NOTICE

**When dumping gray water tank, the backflow preventer must be opened to prevent the gray water tank from air locking. Ensure the backflow preventer is closed before traveling.**

### BLACK TANK FLUSH PORT

Your Oliver comes standard with a black tank flush port on the street side near the bottom of the unit; this allows you to connect an outside water supply and rinse out your black tank.

1. Hook up the appropriate hose to the black tank flush inlet. The plumbing to the black tank is designed to not allow waste from the black tank to feed back to the inlet. You do not have to worry about contaminating your hose.
2. Watch the tank gauge on the See Level monitor and turn off the water before full.
3. Drain the tank into an approved dumping location.



### WARNING

- › DO NOT overfill the black tank (15 gallons).
- › DO NOT open the black tank dump valve until you are ready to empty the tank in an appropriate sewage location.



### CAUTION

**DO NOT use the tank flush valve unless the tank termination valve is in the open position. This can result in an unsanitary condition leading to illness or personal injury.**



## WATER SYSTEM TROUBLESHOOTING

Your plumbing system may develop problems over time. Most of these problems can be greatly reduced, if not eliminated altogether, by following a schedule of planned inspections and maintenance. Neglect of proper maintenance procedures is the usual cause of most water system issues.

Road vibrations and excessive pressure from some city water sources are the main physical causes of water system damage. It is important to inspect all plumbing joints and fittings often for cracks and leaks. Water leaking from a plumbing joint can cause considerable damage if left unchecked. Periodically, check all plumbing connections to ensure they are tight and not leaking.

If the pump is running and all the faucets and valves are closed, a leak may be present somewhere in the freshwater system. When the leaking fitting has been identified, turn off any external water source and turn off the water pump before attempting to stop the leak by tightening.



### CAUTION

**DO NOT over-tighten. Plastic fittings rarely need to be tightened with a wrench. If these fittings leak after tightening, disconnect the fitting and check for dirt, scale, or other foreign substances that may be causing the leak. Clean the fitting thoroughly and reinstall. If leaking persists, shut off the water supply until the fitting can be properly replaced.**

## TERMINATION VALVE MAINTENANCE

During the camping season, use a slide valve lubricant. Two to four ounces of this watersoluble additive is poured down the drain into the gray tank and flushed down the toilet into the black tank to lubricate the inside of the dump valve blades and to coat the inside of the drains and tanks to aid in complete draining and trouble-free valve operation.

## WINTERIZATION

Proper winterization procedures of plumbing systems will typically be all that is necessary to prevent the damage caused by freezing. Freezing damage can harm any component of the system, including the water tanks, toilet, pump, and all piping. Be sure to follow the winterization process outlined below. Local climates vary, and winter maintenance needs may be affected.

If the Oliver is used in cold weather and left unheated for an extended period, the water in a tank or drain line may freeze. If this occurs, you should take immediate steps to thaw it before damage to the system occurs. **DO NOT** continue to use water system components if such a condition exists. If damage has occurred, make sure to have it repaired before using it again.



### WARNING

**DO NOT use automotive antifreeze. Automotive antifreeze is poisonous and not for use in potable water systems. Only use antifreeze suitable for drinking water systems. Failure to do so could result in serious injury or death!**

Objective Summary: Prepare the travel trailer for winterization when it will not be in use to protect from freezing.

#### Required Tools/Items:

- 1 and 1/16th socket, wrench, and extension (for Suburban Water Heaters)
- 3 Gallon or larger bucket for draining water heater (if indoors)
- 3 gallons of non-toxic, concentrated RV antifreeze
- One 24-inch hose with male threaded end
- Antifreeze Hand Pump Kit

#### WINTERIZATION PROTOCOL:

Before we begin, please ensure your Black, Gray, and Freshwater tanks are empty.

NOTE: We do not recommend using compressed air to winterize your Oliver Travel Trailer. Doing so may damage your plumbing system.

1. The first step in the winterization process is to turn off the gas on all propane gas tanks connected to your travel trailer.
2. Next, turn off your water heater at the power switch. If your travel trailer is equipped with a Truma tankless water heater, you will also have to turn off the switch outside on the water heater itself.
3. Next, turn off the water pump and then turn on the hot and cold water at any faucet to depressurize the water system. Once water ceases to flow from the faucet, turn the faucet handles to the off position.
4. Next, you will need to close the by-pass valve on your Suburban or Truma water heater.



**Rear View of Suburban Water Heater**



**Valve Open**  
*(Allows water into water heater)*



**Water Heater Bypassed**  
*(Does not allow water into water heater)*

**Rear View of Truma Water Heater**



**Valve Open**  
*(Allows water into water heater)*



**Water Heater Bypassed**  
*(Does not allow water into water heater)*

**The handle should be pointed toward the hose on both models to bypass the water heater.**

NOTE: You can access the by-pass valve through the curbside seat access panel below the bedding.

5. The by-pass valve will be located near the back of the water heater.
6. Turn the by-pass valve so the handle points toward the rear of the travel trailer.
7. Next, turn the water pump valves so that they are in the winterization valve configuration.
8. You will find the pump and valves inside the camper under the curbside bed or seating area.
9. Configure the valves for winterization. See valve configuration diagrams.
10. Next, attach a hose approximately 2 feet in length to the winterization inlet located at the curbside rear of the travel trailer.

Rear Water Inlet located to the right of the rear bumper:



11. Place the end of the hose into a gallon jug of non-toxic RV antifreeze. **DO NOT** dilute the antifreeze before pumping it into your plumbing system. It is important that you use only concentrated RV antifreeze for winterization.

**NOTE: You will need about 3 gallons of RV antifreeze.**

12. Now, go inside the travel trailer and turn on the water pump
13. Turn on the cold water at the kitchen faucet and let it run until the flow turns from water to antifreeze and turn it off. Repeat this step for the hot water as well.
14. In the bathroom, turn on the cold water at the vanity sink until the flow turns from water to antifreeze and turn it off. Repeat this step for the hot water as well.
15. Next, open the lid on the toilet and press the flush lever until the flow turns from water to antifreeze.
16. Ensure some antifreeze remains in the bowl to keep the seal lubricated.
17. Next, at the outside wash station located at the rear street side of the trailer, turn on the cold water and let it run until the flow turns from water to antifreeze.
18. Turn off the cold water and repeat the same steps with the hot water as well.
19. Then, go inside the travel trailer and turn off the water pump.
20. Next, connect an antifreeze hand pump to the fresh tank fill inlet on the street side, rear of the travel trailer and insert the other end into a gallon of RV antifreeze.
21. Prime the hand pump and pump 4 times to fill the line that runs to the freshwater tank. Disconnect the hose.
22. Locate the black tank flush inlet on the street side of the travel trailer and connect the hand pump hose to the inlet.
23. Prime the hand pump and pump 5 times to fill the line that runs to the black tank.
24. Remove the hose from the inlet.
25. Finally, go inside the travel trailer and pour around two cups of antifreeze into the kitchen sink drain, the bathroom vanity sink drain, and the shower pan to keep the P-traps from freezing.

26. Next, you will need to drain your water heater.
27. If you are indoors, place a large bucket below the water heater door before beginning the next step so you can catch the water as it drains.

#### SUBURBAN WATER HEATER WINTERIZATION

### CAUTION

Use extreme caution during this process as some residual hot water may still be in the water heater tank. Failure to do so may result in a scalding injury.

**NOTE:** The following three steps pertain only to the Truma AquaGo water heater.

#### TRUMA AQUAGO WINTERIZATION

28. If your unit is equipped with a Truma AquaGo, drain the water heater by lifting up the black tab while pulling down the yellow Easy-Drain Lever. Doing so will eject the unit's inlet filter which should NOT be reinstalled while the travel trailer is winterized.

### CAUTION

Leaving the Truma water filter installed may trap residual water, which may freeze and cause damage to the water heater. Do not reinstall the water filter until de-winterization.

29. If you have the AquaGo Electric Antifreeze Kit installed, you will need to unplug it before draining your Truma water heater.
30. Once the water has been drained, lift up on the Easy-Drain lever and lock it in place.

#### DE-WINTERIZATION

1. First, attach a hose approximately 2' in length to the winterization inlet located at the curbside rear of the travel trailer.
2. Place the end of the hose into a 5 gallon container of fresh water.
3. Go inside your travel trailer and close the by-pass valve on your Suburban or Truma water heater ensuring that the valve is pointing toward the rear of the travel trailer. (You can access the water heater by-pass valve through the curbside access panel below the bedding.)
4. Next, configure the water pump valves for winterization. (See valve configuration diagrams)
5. Now, turn on the water pump.
6. At this point, you will turn on the cold water at the kitchen faucet and let it run until the flow turns from antifreeze to water. Repeat this step for the hot water as well.

7. In the bathroom, turn on the cold water at the vanity sink until the flow turns from antifreeze to water and turn it off. Repeat this step for the hot water as well.
8. Next, open the lid on the toilet and press the flush lever until the flow turns from antifreeze to water
9. Now, at the outside wash station located at the rear street side of the trailer, turn on the cold water and let it run until the flow turns from antifreeze to water. Repeat for the hot water as well.
10. Turn off your water pump.
11. Ensure the fresh tank drain valve is open.
12. Next, connect a pressurized potable water source to the fresh tank fill inlet and turn on the water.
13. Allow the water to flow for a few minutes and then turn off the water.
14. Once all water has drained from the fresh tank, close the fresh tank drain valve.
15. Reset the valve configuration to "Normal Valve Configuration".
16. Perform the sanitization process before the camper is ready for use.

#### SANITIZATION

### WARNING

**DO NOT** mix bleach with vinegar or other acids. Doing so will result in the creation of chlorine gas. Chlorine gas exposure may result in serious injury or death.

Sanitize the plumbing system at least once annually. It is also appropriate to sanitize the plumbing system under the following circumstances:

- › Before initial use
- › After de-winterization
- › After extended periods of non-use
- › Whenever there is suspicion of contamination

**NOTE:** Do not sanitize the unit while it is winterized, you must first de-winterize the system.

1. Ensure that the freshwater tank is empty, and the fresh tank drain valve is closed.
2. First, attach a hose approximately 2ft in length to the winterization inlet located at the curbside rear of the travel trailer.
3. Place the end of the hose into a solution of 1 gallon of water mixed with 1/2 cup of bleach.

 **WARNING**

**DO NOT** run bleach solution through the water heater. You must bypass the water heater using the bypass valve.

4. Go inside your travel trailer and close the by-pass valve on your Suburban or Truma water heater ensuring that the valve is pointing toward the rear of the travel trailer. (You can access the water heater by-pass valve through the curbside access panel below the bedding.)
5. Ensure that the valve configuration is in the "Fresh Tank Fill" configuration.
6. Turn the water pump on and let the pump pull the bleach water solution into the fresh tank.
7. Once all the solution has been pumped into the freshwater tank, turn the water pump off.
8. Connect your freshwater hose to the fresh connection port and turn the water on filling the freshwater tank to 100%.
9. Once the tank is full, let the solution sit in the tank for at least 10-15 minutes.
10. Change the water pump valve configuration to the "Normal Valve" configuration.
11. Next, turn the water pump on and allow it to pressurize the system.
12. Now, turn on the cold water at the kitchen, bath, and exterior faucets to pull some of the bleach solution through the freshwater lines. Repeat for the hot water as well. (30 seconds for each faucet is ample time).
13. Open the fresh tank drain valve to allow bleach water to drain from the tank.
14. After the tank is empty close the valve.
15. Again, fill the tank to 100%.
16. Now, turn on your kitchen, bath, and exterior cold-water faucet to pull some of the fresh water through the freshwater lines. Repeat for the hot water as well. (30 seconds for each faucet is ample time).
17. Open the fresh tank drain valve to allow the fresh water to drain from the tank.
18. After draining the fresh water out of the tank, close the fresh tank drain valve. The camper is now ready for use.

**DECALCIFICATION OF PLUMBING SYSTEM**
 **WARNING**

**DO NOT** mix bleach with vinegar or other acids. Doing so will result in the creation of chlorine gas. Chlorine gas exposure may result in serious injury or death.

**NOTICE**

- De-calcifying the water heater should be done separate from the fresh water fixtures such as the faucets and toilet, as vinegar is used in the main fresh water system lines but should not be used in the water heater.

You can preform the water heater de-calcification prior to performing the vinegar flush or at a completely different time. The Truma unit will inform you when it is necessary to decalcify. Follow the guidelines outlined in the Truma AquaGo Section of this Manual.

- The use of a water filter does not protect the plumbing from calcification.

1. Place 3 gallons of vinegar at the rear water inlet.
2. Attach a hose approximately 2' long to the inlet and place the other end in a gallon jug of vinegar.
3. Go inside your travel trailer and close the by-pass valve on your Suburban or Truma water heater ensuring that the valve is pointing toward the rear of the travel trailer (you can access the water heater by-pass valve through the curbside access panel below the bedding).
4. Ensure that the valve configuration is in the "Winterization" configuration.
5. Next, turn the water pump on and allow it to pressurize the system.
6. Now, turn on the cold water at the kitchen faucet to pull some of the vinegar through the freshwater lines. Repeat for the hot water as well (15-20 seconds for each faucet is ample time).
7. Flush the toilet twice.
8. Turn off the water pump and reconfigure the valves to the "Normal Valve" configuration.
9. Next, connect a pressurized potable water source to the city water inlet and turn on.
10. Now, turn on the cold water at the kitchen and bath faucets to pull some of the fresh water through the freshwater lines. Repeat for the hot water as well (15-20 seconds for each faucet is ample time).
11. The camper is now decalcified.

**NOTE:** In some cases you may have to use more than 3 gallons of vinegar to clean out calcium buildup in the lines and at the fixtures. If this is the case, then simply start over with step number one with a new gallon of vinegar and continue until the system has been completely decalcified.

# LEGACY ELITE II PLUMBING SYSTEM

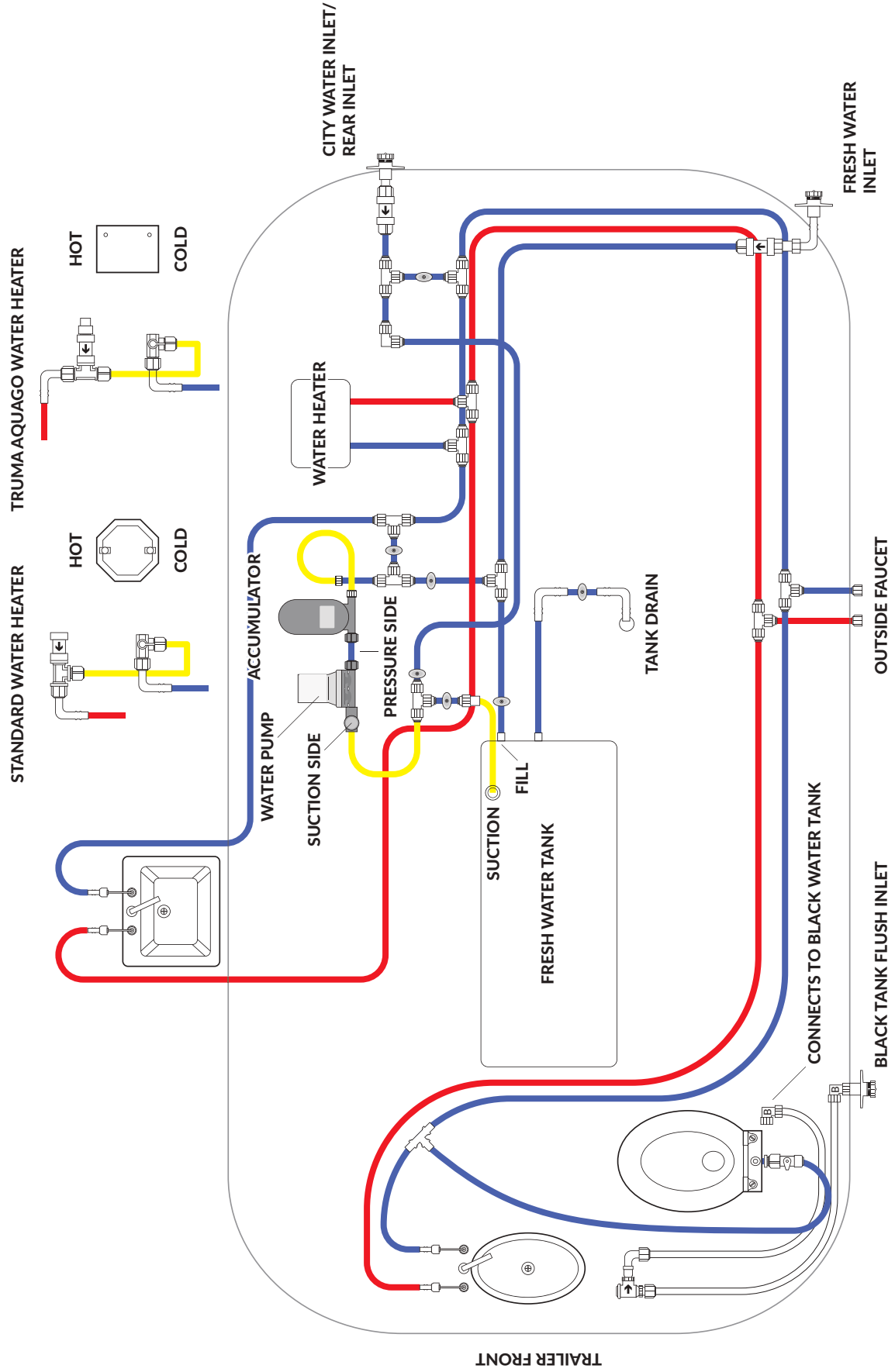

## PROPANE

### OVERVIEW

The propane tanks are stored in the fiberglass propane tank housing located at the front of your travel trailer. Your Oliver comes standard with two 20 pound propane tanks.

The propane system helps operate several components on your travel trailer. The water heater, furnace, and exterior propane quick connects all work using propane as fuel. Read all manufacturer appliance literature, including the information on the LP bottles and regulator, provided in the unit packet, and follow any instructions. Refer to manufacturers' manual.



### DANGER

Always turn off your propane tanks while traveling.

### PROPANE TANK HOUSING

The propane tank housing is equipped with a removable lid that allows you full access to the tanks.

1. The housing lid is held in place by two easy-to-use latches. To release the latch, simply pull the latch back from the top.
2. Once both latches have been released, carefully lift the fiberglass lid up and over the propane tanks inside.
3. The two propane tanks are each tightly secured in the propane tray mounted to the frame. The securing mechanism also holds the propane regulator in place.
4. If you are simply needing to open or close the tank or access the regulator controls, you can also simply open the round deck port located on the front of the housing lid for quick access.

### USING THE REGULATOR

To supply gas to the components that use propane, you will need to open the valves on the propane tanks. The regulator controls the flow of propane throughout the LP lines. The two-stage automatic changeover regulator controls the flow of propane throughout the LP lines.

1. Point the changeover lever to the left or right to indicate your primary propane tank. When gas is present in your primary tank, the indicator on the front of the regulator will be green.
2. Once your primary tank is depleted, the automatic changeover function of the regulator will automatically switch to the reserve tank and the indicator will be red, letting you know the primary tank is depleted and the reserve tank is now being used.
3. If needed, you can point the changeover lever toward your reserve tank and view the indicator to let you know how much gas remains in the reserve tank.

### USING THE QUICK CONNECTS OPTION

Most propane grills or campfires come with a hose that connects directly to a propane bottle. In order to use the propane quick connects on your trailer, you will need a hose that uses a 1/4 inch male NPT quick connect fitting. A propane hose is not supplied with your travel trailer.

1. Turn the lever on the quick connect to the OFF position.
2. Next, pull the dust cap off the quick connect, push the sleeve back on the connection and insert the male fitting into the female quick connect socket.
3. Push the fitting in until you feel it lock.
4. Turn the lever on the quick connection back to the on position to open the flow of propane to your grill, or other propane components.

### REPLACING OR REMOVING THE TANKS

1. To remove your propane tanks for refilling, first, ensure the tank is turned off and unscrew the hose connection by turning the connector counter-clockwise.
2. Between the tanks, remove the large wing-nut by turning it counter-clockwise until it comes off the threaded rod and then lift the regulator up and set it to the side.
3. Now, lift the bar that secures the two tanks and remove or allow it to drop between the tanks.
4. Carefully lift the tank from the propane housing.
5. Once the propane tank is refilled, reverse the steps to secure the tanks inside the propane housing.



## EXTERIOR

### ENTRY STEPS

A two step entry system is provided as standard equipment on all Oliver Travel Trailers. The steps are held in place by a detent on each side. Lift up on the steps and pull forward, then fold out the bottom step. To retract the steps, fold the bottom step and lift the steps out of the detent and push them back to the original stored position.

Make sure that the steps are secure in the retracted position before moving the Oliver Travel Trailer. Make sure to keep fingers away from the sliding mechanism when extending or retracting the steps.

### ENTRY DOOR

The entry doors consist of both the exterior door and the screen door. The screen door is used for ventilation when the Oliver is parked. Always use the door retainer latch if you want to leave the door open. Failure to do so may result in damage to the door.

#### WARNING

- › **DO NOT** attempt to drive or pull your trailer with the doors open.
- › **DO NOT** use exterior door retainer during windy conditions.

### EXTERIOR STORAGE

The Oliver Legacy Elite II comes equipped with a basement storage compartment. The basement storage can be accessed from the inside or the outside of the trailer. From the outside, the basement storage is located on the rear street side of the trailer. It is secured by a marine-style latch that can also be locked using the small key found on the supplied key ring. You will find an LED light mounted inside that conveniently illuminates the entire storage area. To turn the light on or off, reach inside and simply toggle the switch built into the latch as needed.

### AWNING

All Oliver Travel Trailers come standard with a powered curbside awning. On Legacy Elite II models, we also offer an optional awning available on the street side of the trailer. Before you open your awning, be sure that you have enough open space next to the side of the trailer to fully extend the awning open.

#### WARNING

- › **When periods of rain and/or high wind are expected, the awning must be closed. Never leave the awning open and unattended.**
- › **All awnings must be closed prior to moving the vehicle for any reason. As an extra safety precaution, a visual check that every awning is fully closed is required.**
- › **Before using your awning, ensure that the area into which the awning will be deployed is free of obstructions (trees, walls, pillars, posts, other vehicles etc.).**
- › **Damage caused by failure to comply with these instructions is not covered by warranty.**

### AWNING REMOTE CONTROL

You will find the remote in the storage pouch included with this manual. Ensure it is secured in a safe place while in transit to prevent damage.



↑ Toggle through channels (If equipped with dual awnings) ↓  
 Channel 0 Controls both Awnings  
 Channel 1 Controls Curbside Awning  
 Channel 2 Controls Street Awning

#### NOTICE

**Before using the remote, ensure the awning power switch(es) on the main switch panel are in the ON position. Always close the awning and turn off the power switch before traveling. Be sure to check for debris on the awning before retracting.**

On your remote, you will find controls for opening and closing the awning along with buttons to turn the integrated LED lights on or off. The powered awning also features a motion sensor. In the case the sensor detects strong winds, the awning will automatically close. The sensitivity of the sensor can be adjusted if necessary. See your awning manual for more details.

For operating instructions, adjustments, and troubleshooting, view the manufacturer's manual.

**STORAGE BASKET**

*(Optional Equipment)*

If installed, the optional storage basket will be secured on the front of your travel trailer. It is useful for transporting generators or other camping accessories.

 **WARNING**

- › Ensure that the contents of the storage basket are properly secured.
- › **DO NOT** exceed the storage basket's **MAXIMUM WEIGHT CAPACITY** of 150 LBS.
- › **NEVER** operate a portable generator in this basket.
- › **CHECK** with your generator's manufacturer to determine a safe operating distance.
- › **ALWAYS CHECK** whether your trailer's weight is properly distributed.

**REAR BUMPER ACCESSORY RECEIVER**

*(Optional Equipment)*

This accessory receiver is useful for an RV-approved bike rack or other compatible accessories that fit a 2" receiver.

 **WARNING**

- › **DO NOT** exceed this receiver's **MAXIMUM WEIGHT CAPACITY** of 150 LBS. (This includes both racks and baskets, as well as their contents).
- › **ALWAYS CHECK** whether your trailer's weight is properly distributed.
- › **DO NOT** modify this receiver.
- › **DO NOT** exceed a total length of 31" from the end of the receiver to the outside of the attached accessory.

**EXTERIOR FOLDING TABLE**

 **WARNING**

**NEVER** exceed the weight limit of 20lbs on the table.

Your travel trailer is equipped with an exterior folding table that offers an ideal surface for use while cooking outside.



*Exterior table in stowed position*



*Exterior table in up position*

To use the table, pull the latch and lift the table up. The table is equipped with hardware that will lock the table in the upright position.

To collapse the table, press the clips on the bottom of both arms and push the table down. The table should lock in the stowed position when pushed down all the way.

## INTERIOR

### MAXXAIR CABIN FAN

The MaxxAir fan installed in your Oliver functions as an effective air exhaust or intake, and should be used while cooking. The 12-volt fan is operated either remotely or using the built-in switch panel. The remote will be located in the storage pouch included with this manual. The vent cover on the fan features a curved design and allows you to keep your fan open during the rain or even while in transit.

For operating instructions and troubleshooting, view the manufacturer's manual.

### MAXXAIR BATH FAN

The bathroom exhaust fan is located in the ceiling and is easy to operate.

For operating instructions and troubleshooting, view the manufacturer's manual.

### HEATING & COOLING PACKAGES

There are two component packages for heating and cooling your travel trailer. Both packages use the Truma VarioHeat furnace.

1. Standard Package: Truma VarioHeat furnace, Dometic A/C & Suburban water heater.
2. Optional Upgrade Package: Truma VarioHeat furnace, Truma Aventa Eco A/C, and Truma AquaGo on-demand water heater.

### TRUMA COMPONENTS & CP PLUS CONTROL PANEL

The standard Truma furnace, optional Truma A/C, and optional Truma AquaGo Water Heater are controlled by the Truma CP Plus control panel mounted on the street side upper cabinet.

For operating instructions and troubleshooting, view the manufacturer's manual.

### DOMETIC THERMOSTAT

If your trailer is equipped with the "Dometic Package," the Dometic Capacitive Touch thermostat will be installed to control the Air Conditioner, along with the Truma CP Plus to control the VarioHeat furnace.

For operating instructions and troubleshooting, view the manufacturer's manual.

### GALLEY

The kitchen galley drawers feature soft-close slides and a snap-close feature to provide an additional 10-pound capacity, helping to prevent them from opening in transit. Before traveling, always ensure you fully push the drawers in to activate the snap-close feature.

### COUNTERTOPS

Your trailer comes furnished with our high-quality FiberGranite countertops. See our maintenance section for care instructions.



#### WARNING

FiberGranite is not intended for direct contact with hot pots, pans, etc. Always use a suitable trivet mat.

### COOKTOP

For operating instructions and troubleshooting, view the manufacturer's manual.

### REFRIGERATOR

The Oliver is equipped with a 12V refrigerator/freezer combo.



#### WARNING

Before switching on the unit, always make sure that the batteries are in optimal condition.

For operating instructions and troubleshooting, view the manufacturer's manual.

### FOOD STORAGE

If the recreational vehicle is left for a period of time without use, all foods should be removed from the storage areas and refrigerator. The refrigerator should be turned off and the door propped open for ventilation.

### MICROWAVE

The microwave is located above the refrigerator.

#### NOTICE

It is important to stow away the microwave plate to prevent it from breaking during transit.

For operating instructions and troubleshooting of the microwave or optional convection microwave, view the manufacturer's manual.

### **SHOWER TRACK PACKAGE**

*(Optional Equipment)*

If you ordered the optional Shower Curtain Package, this will transform your Wet bath into a hybrid dry/wet bath.

The shower curtain package allows you to cover your shower door, as well as separate your toilet from the shower, giving you a hybrid bathing area.

### **BATH VANITY**

The vanity is integrated with a waterproof toilet paper dispenser on the side and flushmounted hand towel bar in the front.

For added convenience, we have installed an additional water pump switch in the bathroom on the front of the vanity. You will need to turn this switch on when using the water in the bathroom from your freshwater tank.

### **BATH LIGHT**

The bath light switch is located inside the bathroom, left of the door above the toilet.

### **ENTERTAINMENT SYSTEM**

Your Oliver is equipped with an entertainment system that consists of an onboard Bluetooth Speaker and Smart TV.

### **TELEVISION**

You will find the remote for the smart TV in the storage pouch included with this manual. The TV operates on 120-volt power. If you are camping off-grid and your trailer is equipped with an inverter, you will need to turn the inverter on to operate the TV. If your trailer is not equipped with an inverter and not hooked up to 120-volt power, you will need to install a small inverter in the attic to utilize the TV.

The TV should be stowed while not in use, simply push upward on the bottom of the TV until the mount locks the TV in the stowed position. To unlock the TV from the stowed position, simply push up on the bottom of the TV to unlock and pull the TV down.

For operating instructions and troubleshooting, view the manufacturer's manual.

### **BLUETOOTH SPEAKER**

The sound from the TV can be heard through the onboard Bluetooth speaker. To connect the speaker to your TV, follow the steps outlined below:

1. Turn your Bluetooth speaker and TV ON.
2. On your TV remote, click "settings" button.
3. In the drop-down menu, select Bluetooth devices.
4. Select the "ALP-BT-SPK01" as your device
5. After connecting, you are ready to listen to your device.

**SEATING & SLEEPING**

If you have purchased the Standard Floor Plan, you will find a rear dining table with seating that can be converted to a bed.

**Standard floor plan seating/sleeping conversion:**

1. To convert the rear seating area into a bed, you will need to retrieve the filler panel from the closet. You will find it secured to the left wall.
2. Lift the tabletop off of the legs and set it aside.
3. Turn the collar on the table legs clockwise to loosen.
4. Next, turn the leg counterclockwise to remove it.
5. Place the table in the molded ledges on the foam stripping.
6. Use the filler panel to fill in the extra space in the front.
7. Now simply move the back cushions to fill in the space.
8. Reverse the steps when you want to use the rear dining table again.

If you purchased the Twin Bed floor plan, you will find a rear nightstand that allows you to store personal items inside it. The two twin beds are 75 inches long by 30 inches wide.

You may have purchased the upgraded mattress option. While custom sheets are not currently available, you can use standard bed sheets for these mattresses and use straps or pins to keep them in place.

**DINETTE**

The dinette area of your Oliver is furnished with a table and two seats that easily transform into a sleeping area.

**Dinette seating/sleeping conversion:**

1. Loosen the two threaded fasteners on the bottom of the table that connect to the wall.
2. Lift the dinette table out of the brackets and off the table leg and set it aside.
3. Turn the collar on the table leg clockwise to loosen. Then turn the leg a quarter turn counterclockwise and remove.
4. Place the table between the base of the two dinette seats.
5. Now, simply use your back cushions to fill in the space.

Reverse the steps when you want to use the dinette as a table with seating for two.

For more information about converting the seating areas to sleeping, see our videos on Oliver University: [olivertraveltrailers.com/oliver-university](http://olivertraveltrailers.com/oliver-university)

**TWIN BED SEATING DIAGRAM**



**STANDARD SEATING DIAGRAM**



**TWIN BED SLEEPING DIAGRAM**



**STANDARD SLEEPING DIAGRAM**





## MAINTENANCE

### OVERVIEW

The limited warranty and the limited warranties issued by component manufacturers require periodic service and maintenance and the owner's failure to provide this service and/or maintenance may result in loss of warranty coverage for that item. The owner should review Oliver Travel Trailer's (OTT) limited warranty and the limited warranty of all manufacturers of component parts of your Oliver.

Care and maintenance of the recreational vehicle is an important step in maintaining the safety, dependability, and appearance of the unit. Keep good records of all maintenance performed since these may be necessary for warranty information or may assist in possible repairs needed.

Operational usage and climate may affect the frequency of necessary maintenance. Preventative maintenance is important to the life and enjoyment of any recreational vehicle. Many problems can be caught before they occur. Please do not hesitate to call your dealer with a question on maintenance or care of any items. Always refer to the manufacturers' recommendations located within their operating manual.

### FIBERGLASS

Your Oliver Travel Trailer is composed of finished fiberglass in both inner and outer shells. It requires the same care as a fine automobile's finish. Wash your Oliver at least once a month. Use warm water and a mild detergent to clean the finish. Avoid spraying water directly into the water heater, and furnace vents when washing the Oliver. Remove tree sap, droppings, insects, and tar as soon as possible to avoid staining of the finish.

Any finish will deteriorate with time. Dulling and fading can be increased by exposure to extreme sunlight, air pollutants, and excessive moisture. Surface weathering of fiberglass does not change the strength of the fiberglass.

Regular washing and waxing of exterior surfaces is the best insurance against surface deterioration such as fading, yellowing, or chalking.

Wax fiberglass surfaces at least once a year with standard liquid or paste wax. Make sure to follow the directions for use as outlined by the product manufacturer. Make sure to wash and wax your unit out of the hot sun and when exterior surfaces are cool.

Storage of the Oliver out of direct sun also helps preserve its fiberglass finishes. Physical damage to fiberglass should be taken care of immediately to avoid moisture from entering through breaks, reducing its insulative properties and possibly causing problems with interior walls and components. Cover damages in the fiberglass with plastic, sealing the edges with tape until proper repairs can be made.

**NOTE:** Do not use a rubbing compound or any abrasive cleaner or abrasive cloth on the Oliver. If using a tar and insect remover, make sure it is safe for use on painted surfaces.

### FRAMES

To help reduce corrosion to the frame, we also install sacrificial zinc-anodes in several locations on the bottom of the frame. You will need to check these every few years and replace as needed. You should wash the frame regularly, especially when towing the Oliver in the winter, in areas where road salts are used.

### AXLES & SUSPENSION

The Nev-R-Lube axle(s) equipped on your Oliver are sealed for life. They are warranted for 5-years or 100,000 miles against defects in material and workmanship.

Legacy Elite II models are also equipped with the Dexter EZ-Flex Suspension, which contain bushings that require periodic maintenance by greasing the wet-bolts.

### SEALS & ADHESIVES

It is important to maintain the seals and adhesives of your Oliver Travel Trailer to prevent moisture from entering and destroying your camper. You should inspect the exterior caulk and reseal as needed. Weather, sun, and road vibration will affect the seals and silicone/caulk causing them to dry, crack or separate. Oliver recommends resealing the exterior shell of your camper at least once every year. Refer to maintenance schedule.

### WINDOWS & DOORS

Check the seals around the windows and doors at regular intervals:

- ▶ Make sure that windows remain operative by adjusting and lubricating latches and moving parts annually.
- ▶ Check the condition and operation of the door locks, lubricating as necessary.
- ▶ Use powdered graphite or light oil to lubricate moving parts on doors and windows.
- ▶ Keep screens and windows clean and free of debris to maintain proper operation.
- ▶ Test the operation of all windows occasionally to make sure they are functioning properly.

## DRAINAGE SYSTEM

The drainage system, including holding tanks and associated drain piping, should be periodically inspected for damage. We recommend using a valve lubricant periodically to keep the seals in the blade valves operating smoothly.

## UPHOLSTERY

Cushion seats are subject to normal deterioration and to wear and exposure. Normal protective measures can help ensure longer fabric life. Regular vacuuming will help keep colors fresh and prolong wear.

## ELECTRICAL

The electrical system requires minimal maintenance under normal circumstances. Most electrical maintenance in the recreational vehicle involves the battery. Keeping the battery properly maintained will help to eliminate potential electrical problems. If you experience electrical problems with your travel trailer, make sure to have it checked by a qualified electrician. For AGM and Lithium batteries, see the manufacturer's component manual.

## PROPANE

The hoses, pipes, tubes, and fittings used in your LP system are designed to withstand pressures far exceeding those of the LP system. However, because environment and time can contribute to the deterioration of these components, they must be inspected for wear at regular intervals. Look for signs of deterioration such as cracks or loss of flexibility. When replacing LP components always replace them with components of the same type and rating. Refer to the maintenance schedule. Failure to comply could result in serious injury or death.

### NOTICE

Road vibration can loosen LP gas fittings. It is important to check your LP system for leaks at least every 5,000 miles and whenever the tank is filled. It is also a good idea to have your entire LP gas system checked annually by a qualified LP gas service representative.

## INTERIOR COMPONENTS & SURFACES

- Clean interior surfaces with warm soapy water and a moist cloth. Avoid using abrasive cleaners or ammonia-based cleaners.
  - Keep stainless steel surfaces clean and dry to preserve the surface finish.
  - Do not place hot pans directly on countertops as they can damage or scorch the surface.
- Refer to all literature provided with each of the appliances and follow the maintenance instructions included.

## ROOF TOP COMPONENTS

Inspect roof top components (i.e. vents, AC, solar panels, etc.) for debris and/or damage. While traveling beware of height restrictions.

## LIGHTING

Check the operation of all exterior lights per maintenance schedule. Replace nonfunctioning lights and damaged reflectors immediately.

## CONDENSATION

If condensation is a concern review the following options:

- Utilize a humidity monitor to read humidity in the air.
- Utilize a dehumidifier to achieve 50% or less humidity.
- Use your exhaust fans when cooking and showering.
- Utilize an anti-moisture mattress underlay.

## STORING YOUR OLIVER

When storing the travel trailer, certain precautions need to be taken to protect the camper until you use it again.

1. Park the recreational vehicle on a level surface.
2. Winterize the Oliver as outlined in the winterization section.
3. Clean the recreational vehicle thoroughly, both inside and out, as previously outlined. Remember to empty/clean refrigerator and prop door open for airflow.
4. Turn electrical switches and appliances off.
5. Close all window shades to protect the trailer interior from sunlight.
6. Close all windows, doors, and vents. Cover exterior vents on appliances to prevent moisture and insects from entering during storage.
7. Check the interior of the recreational vehicle periodically while in storage to make sure leaks have not developed or condensation formed that can damage interior components. Condensation can most readily be observed as moisture accumulation on windows and mirrors. To reduce condensation, recommendations are included in condensation section.
8. If snow accumulates on the Travel Trailer, try to remove it as often as you can.
9. Refer to the battery manufacturers manual for proper storage and maintenance of each battery type.



**TIRES**

Tires play an important role in the load carrying capacity of the vehicle. To ensure good tire life, check them often. Inspect the general condition of the tires, as well as the air pressure.

Always check the air pressure when the tire is cold. Tires that are hot from traveling will show high pressures. The maximum tire pressure and the load carrying capacity of the tire are imprinted on each tire sidewall. Always inflate your tires to their correct pressure. Don't over or under inflate. Under inflated tires will run hot, shorten the tire's life and decrease the Oliver safe load limit. Over inflated tires will cause a rough and bouncing ride that can damage RV components or cargo. If pressure checks indicate a tire is losing air, check for signs of valve leakage, penetration or wheel and rim damage.

The way you drive can have a significant effect on the wear and life of tires. High speeds, unusual use of the brakes, taking corners too quickly and bad roads all can contribute to the early wear and failure of your tires. When you drive on surfaces with holes or rocks and other loose objects that can damage tires and cause misalignment, make sure to reduce speed and drive carefully. If you notice damage to a tire such as a bulge, uneven wear or damage by a foreign object or the road, have it inspected and repaired or replaced as needed at a reputable repair facility.

NOTE: Cold tire inflation pressure is defined as a tire that has not been used for three or more hours, or has been driven less than one mile. Tire inflation pressure of a hot tire may show an increase of as much as 6 psi over a cold tire. Measure and adjust tire pressure when the tires are cold.



**WARNING**

- › Some maintenance may require the use of special tools. Do not attempt to service, repair or work on any axle, brake or wheel system unless you have appropriate skills, knowledge and the proper tools. Lack of proper training, failure to follow procedures or use special tools and safety equipment could result in property damage, serious injury or loss of life.
- › When replacing a tire, make sure to replace it with as tire of the same size and specifications. Never use different types if tires together on the RV (i.e. radial and biased-belted). Mixing of tires can cause handling problems, as well as unusual tire wear, both of which can create unsafe or even dangerous driving conditions. If your spare is of a different size be especially careful and use only to get to the nearest repair facility.

**LUG NUT TORQUE SPECS**

It is also important to have the wheel nuts checked regularly to make sure they have not loosened during travel. Follow the schedule for regular wheel nut torque checks. If you suspect that wheel nuts have loosened at any time, have them checked and torqued to proper limits immediately (110 ft/lbs).

**OWNER AWARENESS**

If you suspect or notice cracked or broken wheel stud bolts, they must be replaced, along with adjacent bolts. Adjacent bolts probably also have been weakened due to additional stress placed on them.

Make frequent inspections of wheels and tires, looking for signs of wear or damage. Avoid abusive driving habits, such as hitting curbs, or pot holes at high speed, which can damage tires and wheel components.

**NOTICE**

The proper method of tightening wheel nuts is with a torque wrench, not with an impact wrench or by hand. Because of the importance of having proper torque on wheel nuts, you should have wheels mounted and properly torqued by qualified personnel with the proper tools.

**CHANGING A TIRE**



**WARNING**

- › NEVER change any tire without securely chocking the remaining wheels. Never position yourself under a raised trailer that could fall on you and cause serious injury or even death.
- › Failure to re-tighten wheel nuts as required could allow wheels to come off while the vehicle is in motion, causing loss of control possible collision, serious injury or even death.

Turn on tow vehicle hazard warning flashers. Set emergency brake. If close to moving vehicles, set up flares or warning lights. Chock opposite tire and leave trailer hitched to tow vehicle. Set main tongue jack to stabilize front end.

**REMOVE SPARE TIRE**

The spare tire is located behind the custom formed fiberglass spare tire shell. Be sure to visually inspect the spare tire for any deterioration or damage.

Removing it takes a couple of steps:

1. Flip down license plate holder to access wing nut.
2. Remove wing nut and washer.
3. Remove tire cover.
4. Disconnect wiring for license plate light.
5. Remove the retainer ring holding spare tire.
6. Remove tire.

Slightly loosen the lug nuts on the tire you want to remove. Locate the approved jack points on the steel sub frame. Using a bottle or scissor jack, raise the trailer until the tire clears the ground, then finish loosening and removing them. Pull off the old tire, slide the hubcap out backwards and insert it on spare. Set spare tire evenly on the lug nuts and hand tighten lug nuts. Retract front jack back to travel position and remove all external jacks. Now tighten lug nuts completely. Lug nuts should be torqued to 110 ft/lbs. Place the flat tire in the spare location. Have the damaged tire checked and repaired or replaced. Be sure to have lug nuts re-torqued within 50 miles since they may loosen and every 200 miles thereafter.

#### TIRE SAFETY INFORMATION

This portion of the User's Manual contains tire safety information as required by 49 CFR 575.6.

Section 1.1 contains "Steps for Determining Correct Load Limit - Trailer".

Section 1.2 contains "Steps for Determining Correct Load Limit - Tow Vehicle".

Section 1.3 contains a Glossary of Tire Terminology, including "cold inflation pressure", "maximum inflation pressure", "recommended inflation pressure", and other nontechnical terms.

Section 1.4 contains information from the NHTSA brochure entitled "Tire Safety - Everything Rides On It".

This brochure, as well as the preceding subsections, describes the following items:

- Tire labeling, including a description and explanation of each marking on the tires, and information about the DOT Tire Identification Number (TIN)
- Recommended tire inflation pressure, including a description and explanation of
  - A. Cold inflation pressure.
  - B. Vehicle Placard and location on the vehicle.
  - C. Adverse safety consequences of under inflation (including tire failure).
  - D. Measuring and adjusting air pressure for proper inflation.
- Tire Care, including maintenance and safety practices.
- Vehicle load limits, including a description and explanation of the following items:

- A. Locating and understanding the load limit information, total load capacity, and cargo capacity.
- B. Calculating total and cargo capacities with varying seating configurations including quantitative examples showing / illustrating how the vehicles cargo and luggage capacity decreases as combined number and size of occupants' increases. This item is also discussed in Section 3.
- C. Determining compatibility of tire and vehicle load capabilities.
- D. Adverse safety consequences of overloading on handling and stopping on tires.

#### 1.1 STEPS FOR DETERMINING CORRECT LOAD LIMIT – TRAILER

Determining the load limits of a trailer includes more than understanding the load limits of the tires alone. On all trailers there is a Federal certification/VIN label that is located on the forward half of the left (road) side of the unit. This certification/VIN label will indicate the trailer's Gross Vehicle Weight Rating (GVWR). This is the most weight the fully loaded trailer can weigh. It will also provide the Gross Axle Weight Rating (GAWR). This is the most a particular axle can weigh. If there are multiple axles, the GAWR of each axle will be provided.

If your trailer has a GVWR of 10,000 pounds or less, there is a vehicle placard located in the same location as the certification label described above. This placard provides tire and loading information. In addition, this placard will show a statement regarding maximum cargo capacity. Cargo can be added to the trailer, up to the maximum weight specified on the placard. The combined weight of the cargo is provided as a single number. In any case, remember: the total weight of a fully loaded trailer can not exceed the stated GVWR.

For trailers with living quarters installed, the weight of water and propane also need to be considered. The weight of fully filled propane containers is considered part of the weight of the trailer before it is loaded with cargo, and is not considered part of the disposable cargo load. Water however, is a disposable cargo weight and is treated as such. If there is a fresh water storage tank of 100 gallons, this tank when filled would weigh about 800 pounds. If more cargo is being transported, water can be off-loaded to keep the total amount of cargo added to the vehicle within the limits of the GVWR so as not to overload the vehicle. Understanding this flexibility will allow you, the owner, to make choices that fit your travel needs.

When loading your cargo, be sure it is distributed evenly to prevent overloading front to back and side to side. Heavy items should be placed low and as close to the axle positions as reasonable. Too many items on one side may overload a tire. The best way to know the actual weight of the vehicle is to weigh it at a public scale.



Talk to your dealer to discuss the weighing methods needed to capture the various weights related to the trailer. This would include the weight empty or unloaded, weights per axle, wheel, hitch or king-pin, and total weight.

Excessive loads and/or underinflation cause tire overloading and, as a result, abnormal tire flexing occurs. This situation can generate an excessive amount of heat within the tire. Excessive heat may lead to tire failure. It is the air pressure that enables a tire to support the load, so proper inflation is critical. The proper air pressure may be found on the certification/VIN label and/or on the Tire Placard. This value should never exceed the maximum cold inflation pressure stamped on the tire.

1.1.1. TRAILERS 10,000 LBS. GVWR OR LESS

1. Locate the statement, "The weight of cargo should never exceed XXX kg or XXX lbs.," on your vehicle's placard. See figure 1-1.

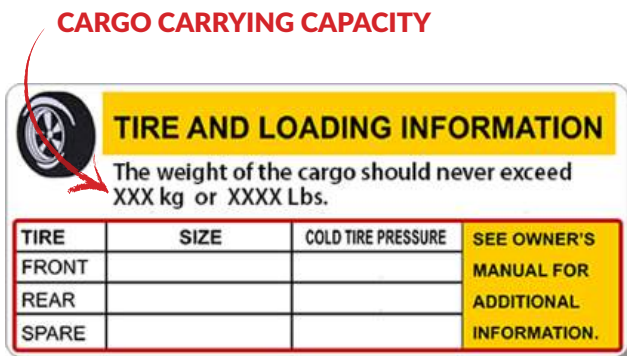

2. This figure equals the available amount of cargo and luggage load capacity.
3. Determine the combined weight of luggage and cargo being loaded on the vehicle. That weight may not safely exceed the available cargo and luggage load capacity

1.1.2. TRAILERS OVER 10,000 LBS. GVWR  
*(These trailers are not required to have a tire information placard on the vehicle)*

The trailer's placard refers to the Tire Information Placard attached adjacent to or near the trailer's VIN (Certification) label at the left front of the trailer.

1. Determine the empty weight of your trailer by weighing the trailer using a public scale or other means. This step does not have to be repeated.
2. Locate the GVWR (Gross Vehicle Weight Rating) of the trailer on your trailer's VIN (Certification) label.
3. Subtract the empty weight of your trailer from the GVWR stated on the VIN label. That weight is the maximum available cargo capacity of the trailer and may not be safely exceeded.

1.2. STEPS FOR DETERMINING CORRECT LOAD LIMIT – TOW VEHICLE

1. Locate the statement, "The combined weight of occupants and cargo should never exceed XXX lbs.," on your vehicle's placard.
2. Determine the combined weight of the driver and passengers who will be riding in your vehicle.
3. Subtract the combined weight of the driver and passengers from XXX kilograms or XXX pounds.
4. The resulting figure equals the available amount of cargo and luggage capacity. For example, if the "XXX" amount equals 1400 lbs. and there will be five 150 lb. passengers in your vehicle, the amount of available cargo and luggage capacity is 650 lbs. (1400- 750 (5 x 150) = 650 lbs.).
5. Determine the combined weight of luggage and cargo being loaded on the vehicle. That weight may not safely exceed the available cargo and luggage capacity calculated in Step # 4.
6. If your vehicle will be towing a trailer, load from your trailer will be transferred to your vehicle. Consult the tow vehicle's manual to determine how this weight transfer reduces the available cargo and luggage capacity of your vehicle.

1.3. GLOSSARY OF TIRE TERMINOLOGY

**Accessory Weight:** The combined weight (in excess of those standard items which may be replaced) of automatic transmission, power steering, power brakes, power windows, power seats, radio and heater, to the extent that these items are available as factory-installed equipment (whether installed or not).

**Bead:** The part of the tire that is made of steel wires, wrapped or reinforced by ply cords and that is shaped to fit the rim.

**Bead Separation:** This is the breakdown of the bond between components in the bead.

**Bias Ply Tire:** A pneumatic tire in which the ply cords that extend to the beads are laid at alternate angles substantially less than 90° to the centerline of the tread.

**Carcass:** The tire structure, except tread and sidewall rubber which, when inflated, bears the load.

**Chunking:** The breaking away of pieces of the tread or sidewall.

**Cold Inflation Pressure:** The pressure in the tire before you drive.

**Cord:** The strands forming the plies in the tire.

**Cord Separation:** The parting of cords from adjacent rubber compounds.



**Cracking:** Any parting within the tread, sidewall, or inner liner of the tire extending to cord material.

**CT:** A pneumatic tire with an inverted flange tire and rim system in which the rim is designed with rim flanges pointed radially inward and the tire is designed to fit on the underside of the rim in a manner that encloses the rim flanges inside the air cavity of the tire.

**Curb Weight:** The weight of a motor vehicle with standard equipment including the maximum capacity of fuel, oil, and coolant, and, if so equipped, air conditioning and additional weight optional engine.

**Extra Load Tire:** A tire designed to operate at higher loads and at higher inflation pressures than the corresponding standard tire.

**Groove:** The space between two adjacent tread ribs.

**Gross Axle Weight Rating:** The maximum weight that any axle can support, as published on the Certification / VIN label on the front left side of the trailer. Actual weight determined by weighing each axle on a public scale, with the trailer attached to the towing vehicle.

**Gross Vehicle Weight Rating:** The maximum weight of the fully loaded trailer, as published on the Certification / VIN label. Actual weight determined by weighing trailer on a public scale, without being attached to the towing vehicle.

**Hitch Weight:** The downward force exerted on the hitch ball by the trailer coupler.

**Innerliner:** The layer(s) forming the inside surface of a tubeless tire that contains the inflating medium within the tire.

**Innerliner Separation:** The parting of the innerliner from cord material in the carcass.

**Intended Outboard Sidewall:** The sidewall that contains a white-wall, bears white lettering or bears manufacturer, brand, and/or model name molding that is higher or deeper than the same molding on the other sidewall of the tire or the outward facing sidewall of an asymmetrical tire that has a particular side that must always face outward when mounted on a vehicle.

**Light Truck (LT) Tire:** A tire designated by its manufacturer as primarily intended for use on lightweight trucks or multipurpose passenger vehicles.

**Load Rating:** The maximum load that a tire is rated to carry for a given inflation pressure.

**Maximum Load Rating:** The load rating for a tire at the maximum permissible inflation pressure for that tire.

**Maximum Permissible Inflation Pressure:** The maximum cold inflation pressure to which a tire may be inflated.

**Maximum Loaded Vehicle Weight:** The sum of curb weight, accessory weight, vehicle capacity weight, and production options weight.

**Measuring Rim:** The rim on which a tire is fitted for physical dimension requirements.

**Pin Weight:** The downward force applied to the 5th wheel or gooseneck ball, by the trailer kingpin or gooseneck coupler.

**Non-Pneumatic Rim:** A mechanical device which, when a non-pneumatic tire assembly incorporates a wheel, supports the tire, and attaches, either integrally or separably, to the wheel center member and upon which the tire is attached.

**Non-Pneumatic Spare Tire Assembly:** A non-pneumatic tire assembly intended for temporary use in place of one of the pneumatic tires and rims that are fitted to a passenger car in compliance with the requirements of this standard.

**Non-Pneumatic Tire:** A mechanical device which transmits, either directly or through a wheel or wheel center member, the vertical load and tractive forces from the roadway to the vehicle, generates the tractive forces that provide the directional control of the vehicle and does not rely on the containment of any gas or fluid for providing those functions.

**Non-Pneumatic Tire Assembly:** A non-pneumatic tire, alone or in combination with a wheel or wheel center member, which can be mounted on a vehicle.

**Normal Occupant Weight:** This means 68 kilograms (150 lbs.) times the number of occupants specified in the second column of Table I of 49 CFR 571.110.

**Occupant Distribution:** The distribution of occupants in a vehicle as specified in the third column of Table I of 49 CFR 571.110.

**Open Splice:** Any parting at any junction of tread, sidewall, or innerliner that extends to cord material.

**Outer Diameter:** The overall diameter of an inflated new tire.

**Overall Width:** The linear distance between the exteriors of the sidewalls of an inflated tire, including elevations due to labeling, decorations, or protective bands or ribs.

**Ply:** A layer of rubber-coated parallel cords

**Ply Separation:** A parting of rubber compound between adjacent plies.

**Pneumatic Tire:** A mechanical device made of rubber, chemicals, fabric and steel or other materials, that, when mounted on an automotive wheel, provides the traction and contains the gas or fluid that sustains the load.



**Production Options Weight:** The combined weight of those installed regular production options weighing over 2.3 kilograms (5 lbs.) in excess of those standard items which they replace, not previously considered in curb weight or accessory weight, including heavy duty brakes, ride levelers, roof rack, heavy duty battery, and special trim.

**Radial Ply Tire:** A pneumatic tire in which the ply cords that extend to the beads are laid at substantially 90° to the centerline of the tread.

**Recommended Inflation Pressure:** This is the inflation pressure provided by the vehicle manufacturer on the Tire Information label and on the Certification / VIN tag.

**Reinforced Tire:** A tire designed to operate at higher loads and at higher inflation pressures than the corresponding standard tire.

**Rim:** A metal support for a tire or a tire and tube assembly upon which the tire beads are seated.

**Rim Diameter:** This means the nominal diameter of the bead seat.

**Rim Size Designation:** This means the rim diameter and width.

**Rim Type Designation:** This means the industry of manufacturer's designation for a rim by style or code.

**Rim Width:** This means the nominal distance between rim flanges.

**Section Width:** The linear distance between the exteriors of the sidewalls of an inflated tire, excluding elevations due to labeling, decoration, or protective bands.

**Sidewall:** That portion of a tire between the tread and bead.

**Sidewall Separation:** The parting of the rubber compound from the cord material in the sidewall.

**Special Trailer (ST) Tire:** The "ST" is an indication the tire is for trailer use only.

**Test Rim:** The rim on which a tire is fitted for testing, and may be any rim listed as appropriate for use with that tire.

**Tread:** That portion of a tire that comes into contact with the road.

**Tread Rib:** A tread section running circumferentially around a tire.

**Tread Separation:** Pulling away of the tread from the tire carcass.

**Treadwear Indicators (TWI):** The projections within the principal grooves designed to give a visual indication of the degrees of wear of the tread.

**Vehicle Capacity Weight:** The rated cargo and luggage load plus 68 kilograms (150 lbs.) times the vehicle's designated seating capacity.

**Vehicle Maximum Load on the Tire:** The load on an individual tire that is determined by distributing to each axle its share of the maximum loaded vehicle weight and dividing by two.

**Vehicle Normal Load on the Tire:** The load on an individual tire that is determined by distributing to each axle its share of the curb weight, accessory weight, and normal occupant weight (distributed in accordance with Table I of CRF 49 571.110) and dividing by 2.

**Weather Side:** The surface area of the rim not covered by the inflated tire.

**Wheel Center Member:** In the case of a non-pneumatic tire assembly incorporating a wheel, a mechanical device which attaches, either integrally or separably, to the non-pneumatic rim and provides the connection between the non-pneumatic rim and the vehicle; or, in the case of a non-pneumatic tire assembly not incorporating a wheel, a mechanical device which attaches, either integrally or separably, to the non-pneumatic tire and provides the connection between tire and the vehicle.

**Wheel Holding Fixture:** The fixture used to hold the wheel and tire assembly securely during testing.

#### 1.4. TIRE SAFETY— EVERYTHING RIDES ON IT

The National Traffic Safety Administration (NHTSA) has published a brochure (DOT HS 809 361) that discusses all aspects of Tire Safety, as required by CFR 575.6. This brochure is reproduced in part below. It can be obtained and downloaded from NHTSA, free of charge, from the following web site:

[www.nhtsa.dot.gov/cars/rules/TireSafety/ridesonit/tires\\_index.html](http://www.nhtsa.dot.gov/cars/rules/TireSafety/ridesonit/tires_index.html)

Studies of tire safety show that maintaining proper tire pressure, observing tire and vehicle load limits (not carrying more weight in your vehicle than your tires or vehicle can safely handle), avoiding road hazards, and inspecting tires for cuts, slashes, and other irregularities are the most important things you can do to avoid tire failure, such as tread separation or blowout and flat tires. These actions, along with other care and maintenance activities, can also:

- Improve vehicle handling
- Help protect you and others from avoidable breakdowns and accidents
- Improve fuel economy
- Increase the life of your tires

This booklet presents a comprehensive overview of tire safety, including information on the following topics:

- › Basic tire maintenance
- › Uniform Tire Quality Grading System
- › Fundamental characteristics of tires
- › Tire safety tips

Use this information to make tire safety a regular part of your vehicle maintenance routine. Recognize that the time you spend is minimal compared with the inconvenience and safety consequences of a flat tire or other tire failure.

### 1.5. SAFETY FIRST— BASIC TIRE MAINTENANCE

Properly maintained tires improve the steering, stopping, traction, and load-carrying capability of your vehicle. Underinflated tires and overloaded vehicles are a major cause of tire failure. Therefore, as mentioned above, to avoid flat tires and other types of tire failure, you should maintain proper tire pressure, observe tire and vehicle load limits, avoid road hazards, and regularly inspect your tires.

#### 1.5.1 FINDING YOUR VEHICLES RECOMMENDED TIRE PRESSURE AND LOAD LIMITS

Tire information placards and vehicle certification labels contain information on tires and load limits. These labels indicate the vehicle manufacturer's information including:

- › Recommended tire size
- › Recommended tire inflation pressure
- › Vehicle capacity weight (VCW—the maximum occupant and cargo weight a vehicle is designed to carry)
- › Front and rear gross axle weight ratings (GAWR— the maximum weight the axle systems are designed to carry).

Both placards and certification labels are permanently attached to the trailer near the left front.

#### 1.5.2 UNDERSTANDING TIRE PRESSURE AND LOAD LIMITS

Tire inflation pressure is the level of air in the tire that provides it with load-carrying capacity and affects the overall performance of the vehicle. The tire inflation pressure is a number that indicates the amount of air pressure— measured in pounds per square inch (psi)—a tire requires to be properly inflated. (You will also find this number on the vehicle information placard expressed in kilopascals (kpa), which is the metric measure used internationally.)

Manufacturers of passenger vehicles and light trucks determine this number based on the vehicle's design load limit, that is, the greatest amount of weight a vehicle can safely carry and the vehicle's tire size. The proper tire pressure for your vehicle is referred to as the "recommended cold inflation pressure." (As you will read below, it is difficult to obtain the recommended tire pressure if your tires are not cold.) Because tires are

designed to be used on more than one type of vehicle, tire manufacturers list the "maximum permissible inflation pressure" on the tire sidewall. This number is the greatest amount of air pressure that should ever be put in the tire under normal driving conditions.

#### 1.5.3. CHECKING TIRE PRESSURE

It is important to check your vehicle's tire pressure at least once a month for the following reasons:

- › Most tires may naturally lose air over time.
- › Tires can lose air suddenly if you drive over a pothole or other object or if you strike the curb when parking
- › With radial tires, it is usually not possible to determine underinflation by visual inspection

For convenience, purchase a tire pressure gauge to keep in your vehicle. Gauges can be purchased at tire dealerships, auto supply stores, and other retail outlets. The recommended tire inflation pressure that vehicle manufacturers provide reflects the proper psi when a tire is cold. The term cold does not relate to the outside temperature. Rather, a cold tire is one that has not been driven on for at least three hours. When you drive, your tires get warmer, causing the air pressure within them to increase. Therefore, to get an accurate tire pressure reading, you must measure tire pressure when the tires are cold or compensate for the extra pressure in warm tires.

#### 1.5.4. STEPS FOR MAINTAINING PROPER TIRE PRESSURE

1. Locate the recommended tire pressure on the vehicle's tire information placard, certification label, or in the owner's manual.
2. Record the tire pressure of all tires.
3. If the tire pressure is too high in any of the tires, slowly release air by gently pressing on the tire valve stem with the edge of your tire gauge until you get to the correct pressure.
4. If the tire pressure is too low, note the difference between the measured tire pressure and the correct tire pressure. These "missing" pounds of pressure are what you will need to add.
5. At a service station, add the missing pounds of air pressure to each tire that is underinflated.
6. Check all the tires to make sure they have the same air pressure (except in cases in which the front and rear tires are supposed to have different amounts of pressure).

If you have been driving your vehicle and think that a tire is underinflated, fill it to the recommended cold inflation pressure indicated on your vehicle's tire information placard or certification label.

While your tire may still be slightly underinflated due to the extra pounds of pressure in the warm tire, it is safer to drive with air pressure that is slightly lower than the vehicle manufacturer's recommended cold inflation pressure than to drive with a significantly underinflated tire. Since this is a temporary fix, don't forget to recheck and adjust the tire's pressure when you can obtain a cold reading.

### 1.5.5. TIRE SIZE

Prop To maintain tire safety, purchase new tires that are the same size as the vehicle's original tires or another size recommended by the manufacturer. Look at the tire information placard, the owner's manual, or the sidewall of the tire you are replacing to find this information. If you have any doubt about the correct size to choose, consult with the tire dealer.

### 1.5.6. TIRE TREAD

The tire tread provides the gripping action and traction that prevent your vehicle from slipping or sliding, especially when the road is wet or icy. In general, tires are not safe and should be replaced when the tread is worn down to 1/16 of an inch. Tires have built in treadwear indicators that let you know when it is time to replace your tires. These indicators are raised sections spaced intermittently in the bottom of the tread grooves. When they appear "even" with the outside of the tread, it is time to replace your tires. Another method for checking tread depth is to place a penny in the tread with Lincoln's head upside down and facing you. If you can see the top of Lincoln's head, you are ready for new tires.

### 1.5.7. TIRE BALANCE AND WHEEL ALIGNMENT

To avoid vibration or shaking of the vehicle when a tire rotates, the tire must be properly balanced. This balance is achieved by positioning weights on the wheel to counterbalance heavy spots on the wheel-and-tire assembly. A wheel alignment adjusts the angles of the wheels so that they are positioned correctly relative to the vehicle's frame. This adjustment maximizes the life of your tires. These adjustments require special equipment and should be performed by a qualified technician.

### 1.5.8. TIRE REPAIR

The proper repair of a punctured tire requires a plug for the hole and a patch for the area inside the tire that surrounds the puncture hole. Punctures through the tread can be repaired if they are not too large, but punctures to the sidewall should not be repaired. Tires must be removed from the rim to be properly inspected before being plugged and patched.

### 1.5.9. TIRE FUNDAMENTALS

Federal law requires tire manufacturers to place standardized information on the sidewall of all tires.

This information identifies and describes the fundamental characteristics of the tire and also provides a tire identification number for safety standard certification and in case of a recall.

#### 1.5.9.1. INFORMATION ON PASSENGER VEHICLE TIRES

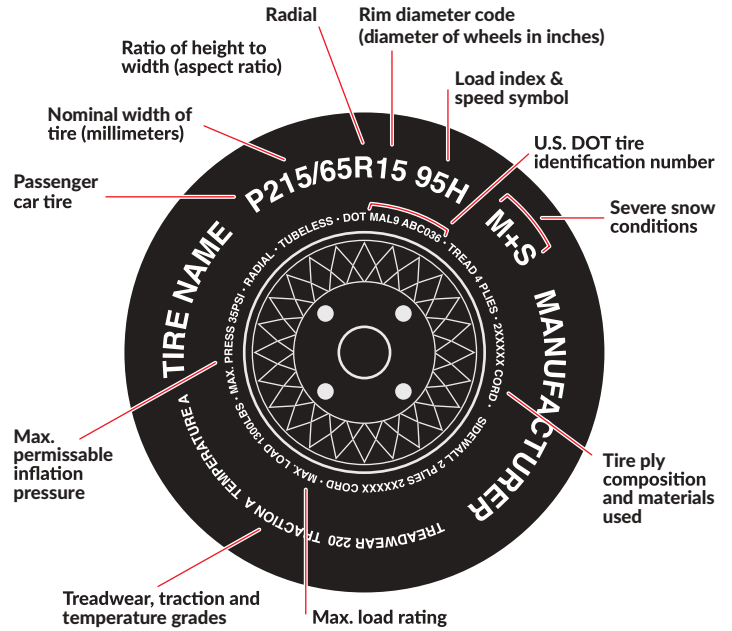

**P:** The "P" indicates the tire is for passenger vehicles

**Next Number:** This three-digit number gives the width in millimeters of the tire from sidewall edge to sidewall edge. In general, the larger this number is, the wider the tire.

**Next Number:** This two-digit number, known as the aspect ratio, gives the tire's ratio of height to width. Numbers of 70 or lower indicate a short sidewall for improved steering response and better overall handling on dry pavement.

**R:** The "R" stands for radial. Radial ply construction of tires has been the industry standard for the past 20 years.

**Next Number:** This two-digit number is the wheel or rim diameter in inches. If you change your wheel size, you will have to purchase new tires to match the new wheel diameter.

**Next Number:** This two- or three-digit number is the tire's load index. It is a measurement of how much weight each tire can support. You may find this information in your owner's manual. If not, contact a local tire dealer.

**NOTE:** You may not find this information on all tires because law does not require it.

**M+S:** The "M+S" or "M/S" indicates that the tire has some mud and snow capability. Most radial tires have these markings; hence, they have some mud and snow capability.



**Speed Rating:** The speed rating denotes the intended speed at which a tire is designed for extended periods of driving. The ratings range from 99 miles per hour (mph) to 186 mph.

NOTE: You may not find this information on all tires because law does not require it.

LETTER RATING	SPEED RATING
Q	99 MPH
R	106 MPH
S	112 MPH
T	118 MPH
U	124 MPH
H	130 MPH
V	149 MPH
W	168* MPH
Y	186* MPH

\*For tires with a maximum speed capability over 149 mph, tire manufacturers sometimes use the letters ZR.

For those with a maximum speed capability over 186 mph, tire manufacturers always use the letters ZR.

**U.S. Dot Tire Identification Number:** This begins with the letters "DOT" and indicates that the tire meets all federal standards. The next two numbers or letters are the plant code where it was manufactured, and the last four numbers represent the week and year the tire was built. For example, the numbers 3197 means the 31st week of 1997. The other numbers are marketing codes used at the manufacturer's discretion. This information is used to contact consumers if a tire defect requires a recall.

**Tire Ply Composition and Materials Used:** The number of plies indicates the number of layers of rubber-coated fabric in the tire. In general, the greater the number of plies, the more weight a tire can support. Tire manufacturers also must indicate the materials in the tire, which include steel, nylon, polyester, and others.

**Maximum Load Rating:** This number indicates the maximum load in kilograms and pounds that can be carried by the tire.

**Maximum Permissible Inflation Pressure:** This number is the greatest amount of air pressure that should ever be put in the tire under normal driving conditions.

1.5.9.2. UTQGS INFORMATION

**Tread Wear Number:** This number indicates the tire's wear rate. The higher the tread wear number is, the longer it should take for the tread to wear down. For example, a tire graded 400 should last twice as long as a tire graded 200.

**Traction Letter:** This letter indicates a tire's ability to stop on wet pavement. A higher graded tire should allow you to stop your car on wet roads in a shorter distance than a tire with a lower grade. Traction is graded from highest to lowest as "AA", "A", "B", and "C".

**Temperature Letter:** This letter indicates a tire's resistance to heat. The temperature grade is for a tire that is inflated properly and not overloaded. Excessive speed, under inflation or excessive loading, either separately or in combination, can cause heat build-up and possible tire failure. From highest to lowest, a tire's resistance to heat is graded as "A", "B", or "C".

1.5.9.3. ADDITIONAL INFORMATION ON LIGHT TRUCK TIRES

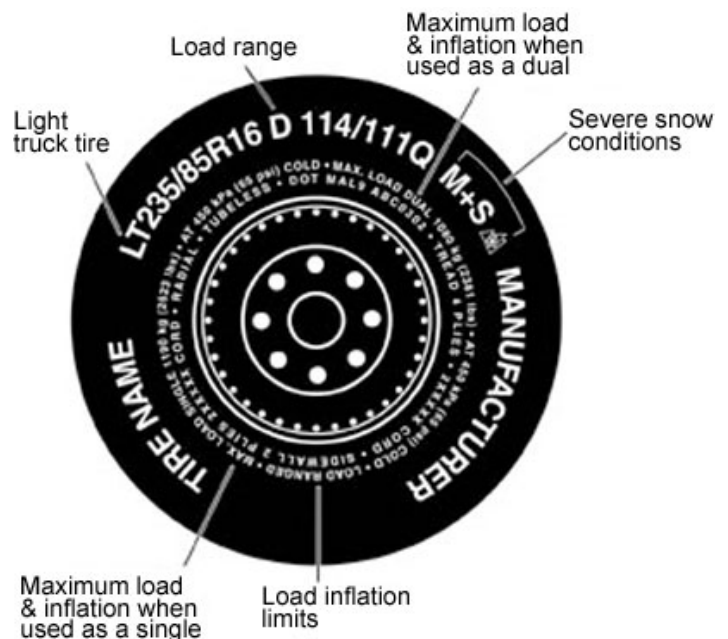

Tires for light trucks have other markings besides those found on the sidewalls of passenger tires.

**LT:** The "LT" indicates the tire is for light trucks or trailers.

**ST:** An "ST" is an indication the tire is for trailer use only.

**Maximum Load Dual KG (LBS.) at KPA (PSI) Cold:** This information indicates the maximum load and tire pressure when the tire is used as a dual, that is, when four tires are put on each rear axle (a total of six or more tires on the vehicle).

**Maximum Load Single KG (LBS.) at KPA (PSI) Cold:** This information indicates the maximum load and tire pressure when the tire is used as a single.

**Load Range:** This information identifies the tire's load-carrying capabilities and its inflation limits.



## 1.6 TIRE SAFETY TIPS

### Preventing Tire Damage

- Slow down if you have to go over a pothole or other object in the road.
- Do not run over curbs or other foreign objects in the roadway, and try not to strike the curb when parking.

### Tire Safety Checklist

- ✓ Check tire pressure regularly (at least once a month), including the spare.
- ✓ Inspect tires for uneven wear patterns on the tread, cracks, foreign objects, or other signs of wear or trauma.
- ✓ Remove bits of glass and foreign objects wedged in the tread.
- ✓ Make sure your tire valves have valve caps.
- ✓ Check tire pressure before going on a long trip.

Do not overload your vehicle. Check the Tire Information and Loading Placard or User's Manual for the maximum recommended load for the vehicle.

### MAINTENANCE SCHEDULE

The following conditions will require more frequent maintenance:

- Heavy usage
- Dusty environments
- Coastal and/or snowy environments
- Highly mineralized water (hard water)

### NOTICE

The wheel lug nuts should be checked approximately every 200 miles. The recommended torque is 110ft/lbs.

### BEFORE EVERY TRIP:

- ✓ Inspect tires and tire pressure (see placard)
- ✓ Inspect 7-pin
- ✓ Inspect brake, turn signals, reverse, and marker lights
- ✓ Inspect coupler operation
- ✓ Breakaway battery inspection

### BI-WEEKLY:

- ✓ Inspect A/C and clean filter

### MONTHLY:

- ✓ Inspect and clean water pump filter
- ✓ Lubricate waste blade valves
- ✓ Inspect LP system
- ✓ Inspect safety breakaway
- ✓ Wash the exterior and apply UV inhibitor or polish
- ✓ Inspect seals and caulk for deterioration
- ✓ Test GFCI function

### EVERY 3 MONTHS:

- ✓ Flush fresh water system
- ✓ Lubricate suspension wet-bolts
- ✓ Inspect suspension components

### EVERY 12 MONTHS:

- ✓ Wax exterior
- ✓ Inspect water heater anode (if equipped)
- ✓ Inspect and grease jacks
- ✓ Inspect furnace
- ✓ Sanitize freshwater system
- ✓ Decalcify plumbing system
- ✓ Inspect Nev-R-Lube axle (every 12 months or 12k miles)
- ✓ Inspect brake linings/magnets



Scan the QR code to access Oliver University online



Scan the QR code to view our catalog of how-to videos on YouTube

DATE: .....

MAINTENANCE NOTES:

.....  
.....  
.....  
.....  
.....  
.....

DATE: .....

MAINTENANCE NOTES:

.....  
.....  
.....  
.....  
.....  
.....

DATE: .....

MAINTENANCE NOTES:

.....  
.....  
.....  
.....  
.....  
.....

DATE: .....

MAINTENANCE NOTES:

.....  
.....  
.....  
.....  
.....  
.....



**MAINTENANCE**

DATE: .....

MAINTENANCE NOTES:

.....  
.....  
.....  
.....  
.....

DATE: .....

MAINTENANCE NOTES:

.....  
.....  
.....  
.....  
.....

DATE: .....

MAINTENANCE NOTES:

.....  
.....  
.....  
.....  
.....

DATE: .....

MAINTENANCE NOTES:

.....  
.....  
.....  
.....  
.....





Oliver Travel Trailers® 2026  
[www.olivertraveltrailers.com](http://www.olivertraveltrailers.com)