

VIP 3000 POWER JACK OWNER'S INSTRUCTIONS

P/N 30826 (WHITE) or P/N 32453 (BLACK)

H&H Engineering VIP 3,000 Power Jack is designed to lift up to 3,000 pounds a full 18". It's design also includes a night light, built-in leveling device, attached foot plate, and an emergency crank handle. An important part of owning and using a VIP Jack is being sure it is properly installed and serviced.

GENERAL SAFETY:

Read and understand the Jack installation instructions. Always block trailer wheel when using the jack. Since there are moving parts inside the jack, be careful of loose clothing, remove or secure loose jewelry (watches, rings, etc.).

BEFORE INSTALLATION:

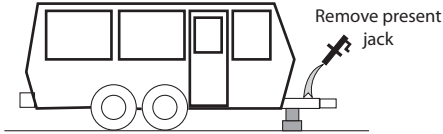

Raise your travel trailer's front end and place blocks or stabilizing jacks under the front "A" frame. Lower the trailer until it rests securely on stabilizing jacks or blocks. Retract present jack and remove.

INSTALLATION:

Install Jack in hole and secure with 3 bolts & 3 internal tooth lockwashers (bolt holes are threaded). The 3 bolts should already be on your trailer. The 3 internal lockwashers are supplied by us (in hardware bag). Attach the foot plate to VIP Jack with .50-20 bolt and .50" lockwasher (supplied in hardware bag).

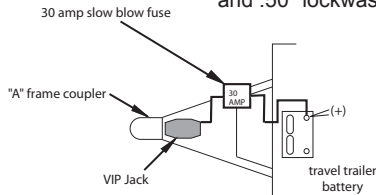

Connect the lead-wire directly to the positive (+) lead of the travel trailer's battery using a twelve (12) gage wire. Be sure the connection is a good one. THE 30 AMP SLO-BLO FUSE MUST BE INSTALLED AS SHOWN.

IMPORTANT

To insure a good electrical ground an internal tooth lock-washer must be in place for this bolt. Make sure powdercoat or paint is removed from "A" frame coupler under washer and that tagged hole is used.

The bolts should already be on your trailer.

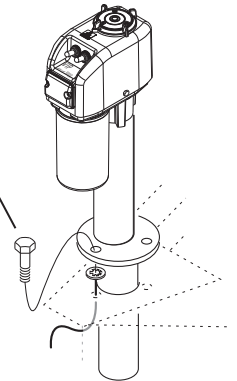

IMPORTANT NOTICE:

If it is necessary to change the position of the powerhead relative to the post and flange (in order to provide clearance between powerhead and LP gas bottle or LP gas cover, or more clearance between the lift gate and the powerhead) loosen set screws and rotate head without lifting off coupling. Retighten set screws when head is in desired position.

INITIAL SET-UP AND HOW TO USE YOUR VIP POWER JACK LEVEL:

1. Install your VIP Power Jack (SEE INSTALLATION above).
2. Place a small level inside your RV on a surface you want to level. This might be a counter top or freezer compartment of a refrigerator.
NOTE: It will be necessary to move this level to check side to side and front to back condition.
3. Check the "inside level", level your trailer from side to side with stabilizing jacks or boards under the wheels.
4. Checking the "inside level", level your trailer front to back using your VIP Power Jack.
5. Carefully adjust the 3 stainless steel screws on the ring that surround the built in bulls-eye level (see picture) until the air bubble is inside the middle circle. Your trailer will then be leveled.

In the future, you can do all your leveling by using your VIP Power Jack built-in level.

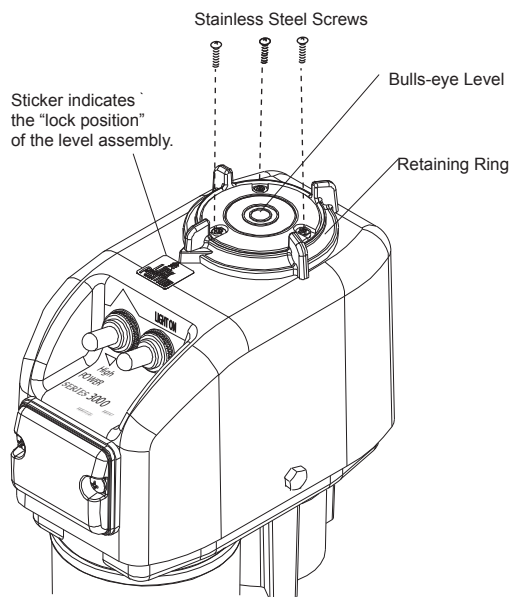

MAINTENANCE:

Once a year, the powerhead should be removed and a liberal amount of grease (preferably a grease with high melting point) applied directly to the coupling on which the drive pin rests.

DO NOT POUR OIL into top of the jack post.

Once a year, the housing cover should be removed and the gears inspected for proper lubrication. Remove 4 screws and tap around edge of housing to free cover.

DO NOT insert screw driver blade! (This may damage mating surfaces.)

Before replacing cover, clean mating surfaces. If lubrication is needed, use Mobilith 460 grease or equivalent.

barker

1125 Watkins Road / PO Box 460

Battle Creek, MI 49016

Phone: 269-965-2371 Fax: 269-965-2389

www.barkermfg.com E-Mail: service@barkermfg.com

© Copyright H&H Engineering 1989

PAGE:	DATE:	FORM #:
1 of 3	20 DEC 11	30842
REV. LETTER:	ECN#:	APPROVED:
F	14481	

VIP 3000 POWER JACK OWNER'S INSTRUCTIONS

P/N 30826 (WHITE) and P/N 32453 (BLACK)

OPERATION (ELECTRIC)

REMEMBER TO KEEP HANDS AND FEET FROM UNDER THE FOOT PLATE WHEN USING POWER JACK.

When VIP Jack reaches the end of its travel (either raising or lowering), the internal clutch activates. Dolly wheels are not recommended.

The JACK will raise and lower by this toggle switch-- NOT the travel trailer.

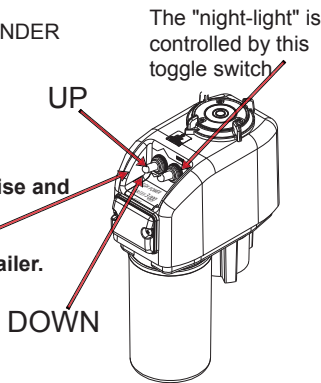

Warning

AVOID THE RISK OF INJURY OR DEATH TO YOURSELF AND OTHERS:

- USE THE JACK FOR LIFTING THE TRAVEL TRAILER ONLY.
- NEVER GET BENEATH THE TRAILER WHEN IT IS SUPPORTED BY THE JACK.
- SUPPORT THE VEHICLE WITH THE APPROPRIATE MEANS.

OPERATION (MANUALLY):

If an electrical failure should occur, the emergency handle may be inserted into the jack post and the jack can be raised or lowered. (Access can be obtained by twisting cap off. NOTE: You do not have to remove or loosen screws on level to remove the level assembly.) If the power-head is removed, crank can still be used to raise and lower jack.

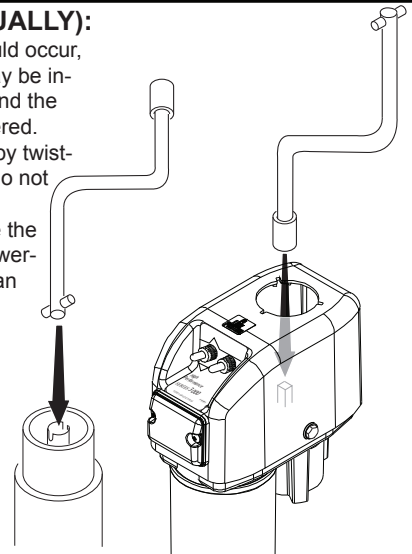

SCHEMATIC WIRING DIAGRAM

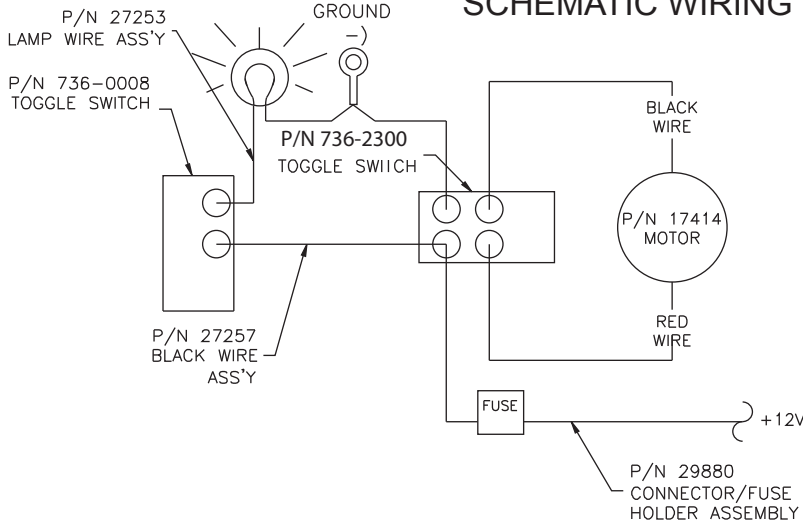

STRAP ATTACHMENT:

1. Press strap (1) onto the stud (2) at the bottom of the cap.
2. Press the retaining ring (3) on stud (2) snug it down against the strap (1).
3. Repeat this process (4) on the stud found on the inside of the cover.

THIS WILL SECURE YOUR CAP.

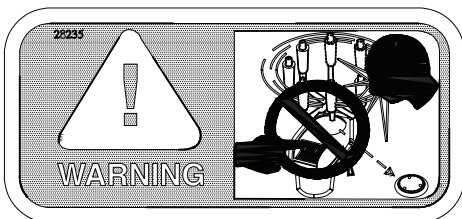
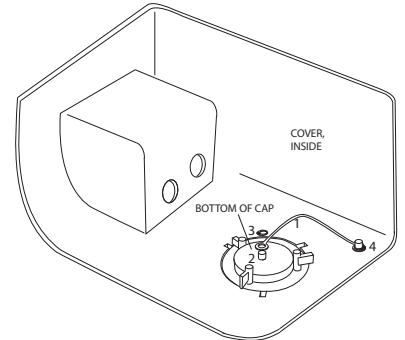

WARNING!!!

Do not use toggle switch with crank handle in place. Breaking this rule will cause serious injury or death.

WARNING

Don't risk serious injury or death in a shearing or squeezing accident. Keep body, hands, and feet away.

19989

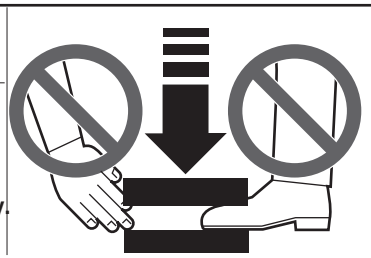

- REMEMBER TO KEEP HANDS AND FEET OUT FROM UNDER THE FOOT PLATE WHEN USING THE POWER JACK!!
- DOLLY WHEELS ARE NOT RECOMMENDED.

BREAKING THESE RULES WILL CAUSE SERIOUS INJURY OR DEATH.

barker

1125 Watkins Road / PO Box 460
Battle Creek, MI 49016
Phone: 269-965-2371 Fax: 269-965-2389
www.barkermfg.com E-Mail: service@barkermfg.com

© Copyright H&H Engineering 1989

PAGE: 2 of 3	DATE: 20 DEC 11	FORM #: 30842
REVISION LETTER: F	ECN#: 14481	APPROVED:

VIP 3000 POWER JACK OWNER'S INSTRUCTIONS

P/N 30826 (WHITE) or P/N 32453 (BLACK)

PARTS:

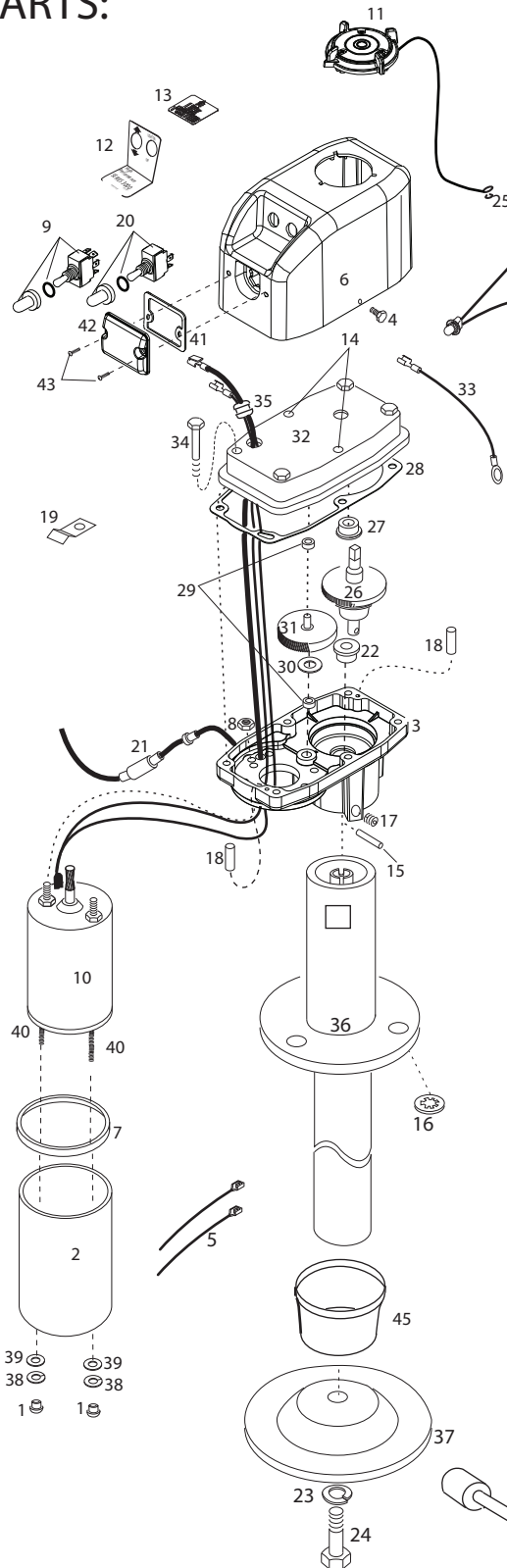

ITEM	PART#	REQ'D	DESCRIPTION
1	613-0000	2	#10-32 ACORN NUT
2	27344	1	MOTOR SLEEVE (WHITE)
2	27276	1	MOTOR SLEEVE (BLACK)
3	30783	1	BASE FINISHED (WHITE)
3	30782	1	BASE FINISHED (BLACK)
4	606-0010	2	#10-16 X .75TEK SCREW (ZINC PLATED)
4	606-0008	2	#10-16 X .75TEK SCREW (BLACK HEAD)
5	16392	2	CABLE TIE
6	27338	1	COVER WHITE MACHINED
6	27259	1	COVER BLACK MACHINED
7	27274	1	MOTOR SEAL
8	611-2100	2	HEX LOCKNUT
9	736-2300	1	TOGGLE SWITCH
10	16263	1	MOTOR
11	30331	1	CAP ASSEMBLY- WHITE
11	30330	1	CAP ASSEMBLY- BLACK
12	30835	1	COVER LABEL
13	30683	1	LOCK INDICATOR LABEL (WHITE)
13	30341	1	LOCK INDICATOR LABEL (BLACK)
14	16434	2	HOLE PLUG
15	623-1216	1	GROOVE PIN
16	619-0003	3	LOCKWASHER INTERNAL TOOTH
17	608-0006	3	SET SCREW .313-18 X .50"
18	621-0004	2	DOWEL Ø.13" X .75
19	17808	1	WIRE CLAMP
20	736-0008	1	TOGGLE SWITCH
21	29880	1	CONNECTOR/FUSE HOLDER ASSEMBLY
22	645-0024	1	BUSHING
23	618-1002	1	LOCKWASHER .50
24	600-0011	1	HEX BOLT .50-20 X .75
25	634-0028	2	RETAINING RING
26	30839	1	TORQUE LIMITER ASSEMBLY
27	641-0009	1	BUSHING
28	29306	1	GASKET
29	80501	2	BUSHING
30	80208	1	WASHER, SPACER
31	28207	1	GEAR DRIVE ASSEMBLY
32	17419	1	COVER MACHINED
32	30774	1	COVER FINISHED (BLACK)
33	27257	1	BLACK WIRE ASSEMBLY
34	605-0012	4	SCREW
35	26236	1	RUBBER GROMMET
36	27335	1	POST ASSEMBLY BLACK
36	31840	1	POST ASS'Y-ALTERED FLANGE-BLACK
37	21349	1	BASE
38	618-1009	2	#10 SPLIT LOCKWASHER
39	617-0071	2	M5 WASHER
40	30850	2	STUD #10-32
41	30313	1	LENS GASKET
42	27262	1	LENS
43	606-5001	2	SCREW #10 X .50 PHILLIPS
44	27253	1	LAMP WIRE ASS'Y
45	10017	1	POST ADAPTER
46	28259	1	CRANK HANDLE

barker

1125 Watkins Road / PO Box 460

Battle Creek, MI 49016

Phone: 269-965-2371 Fax: 269-965-2389

www.barkermfg.com E-Mail: service@barkermfg.com

© Copyright H&H Engineering 1989

PAGE: 3 of 3	DATE: 20 DEC 11	FORM #: 30842
REV. LETTER: I	ECN#: 14481	APPROVED: