

# KING | ONE<sup>PRO</sup><sup>TM</sup>

## KOP4800 Owner's Manual



This manual is for units  
manufactured on or after  
11/16/2020.

Mfg. date is on serial number label.



Label is located on base.

### For use with DISH<sup>®</sup> satellite programming & Wally<sup>®</sup> Receivers



The KING One Pro works with DIRECTV<sup>®</sup>, DISH, and Bell<sup>™</sup> TV. This manual is for DISH subscribers with Wally receivers. Manuals for DISH (with other receivers), DIRECTV and Bell subscribers are available at [kingconnect.com/support](http://kingconnect.com/support).

Use this manual only if you have a Wally receiver.





The satellite TV market is expanding and changing. The information in this manual was accurate at the time of printing. If your KING One Pro Satellite Antenna does not operate as outlined in this manual, please call KING® at (952) 345-8147 or visit our website at *kingconnect.com*.

**KING is not responsible for changes outside of its control.**



**PRODUCT REGISTRATION**

To provide ongoing technical support and to better facilitate warranty processing, please register your product at *kingconnect.com/support*.

**CONTENTS**

INTRODUCTION ..... 2

UNBOX ANTENNA..... 3

APPLY RUBBER FEET ..... 3

POSITION ANTENNA..... 4

OBSERVE CAUTIONS WHEN CONNECTING ANTENNA..... 5

CONNECT ANTENNA ..... 6

SCAN FOR SATELLITES..... 8-17

    NEW AND UNACTIVATED WALLY RECEIVER ..... 8-13

    STANDARD OPERATION ..... 14-17

ENABLE THE ALARM (OPTIONAL) ..... 18-19

SECOND RECEIVER OPERATION..... 20

ACCESSORIES ..... 21

SECURE THE ANTENNA..... 22

TROUBLESHOOTING..... 22-25

MODE CHART ..... 25

LIMITED WARRANTY ..... 26

FCC GUIDELINES ..... 27



If you switch services or replace your Wally with a different model receiver, you will need the appropriate on-line manual to configure the antenna for your new service or receiver. Go to *kingconnect.com/support*. Go to the Satellite Products section. Under KING One Pro Premium Satellite Antenna, choose from the following:

**MANUAL: DIRECTV** (KING One Pro DIRECTV Owner’s Manual)

**MANUAL: ViP RECEIVERS** (KING One Pro DISH ViP Receiver Owner’s Manual)

**MANUAL: LEGACY RECEIVERS** (KING One Pro DISH Legacy Receiver Owner’s Manual)

**MANUAL: BELL** (KING One Pro Bell Owner’s Manual)

# INTRODUCTION

## Thank you for choosing the premium **KING One Pro Portable HDTV System!**

### IMPORTANT SAFETY AND CARE INFORMATION

1. Keep the Quick Reference Guide and Installation Guide that came with your KING One Pro in a safe place for future reference. You may also print this on-line manual and keep it for future reference as well.
2. Follow all instructions and warnings. Set up and operate the KING One Pro in accordance with the instructions.
3. To avoid risk of electric shock, unplug your receiver before connecting/disconnecting the KING One Pro in damp or wet conditions.
4. Tighten all of the coax cable connections only by hand. If you use a wrench, you may over-tighten the connections and damage your equipment.
5. Always handle the KING One Pro carefully. Do not drop the KING One Pro. Avoid excessive shock or vibration to the KING One Pro.
6. Use caution when carrying the KING One Pro. Always carry the KING One Pro by the handle.
7. Do not remove the cover of the KING One Pro without authorization. Doing so will void the limited warranty.
8. Do not stack the KING One Pro on top of or below other electronic devices as this can cause heat build-up or block the satellite signal from reaching the KING One Pro.
9. Do not operate or store near any indoor or outdoor heat source such as radiators, heat registers, stoves, barbecues, campfires, or other items that produce heat.
10. Servicing may be required if the unit has been dropped or damaged in any way or if the unit does not operate normally. Call KING Customer Service at (952) 345-8147.
11. Do not power wash the KING One Pro.
12. Do not submerge the KING One Pro or place in standing water.
13. Keep the enclosure clean from dirt, bugs, and other debris by hand washing with mild soap and water.
14. Do not coat or paint the KING One Pro with any substance.

The KING One Pro has been designed to be maintenance and trouble free. If not using the KING One Pro for long periods of time, it is recommended that you set up the system on a quarterly basis (every three months) to keep all moving parts of the KING One Pro in good working order.

If you have any comments or questions, please contact KING Customer Service at (952) 345-8147, or by email at [help@kingconnect.com](mailto:help@kingconnect.com).

**QUESTIONS? (952) 345-8147**

# UNBOX ANTENNA

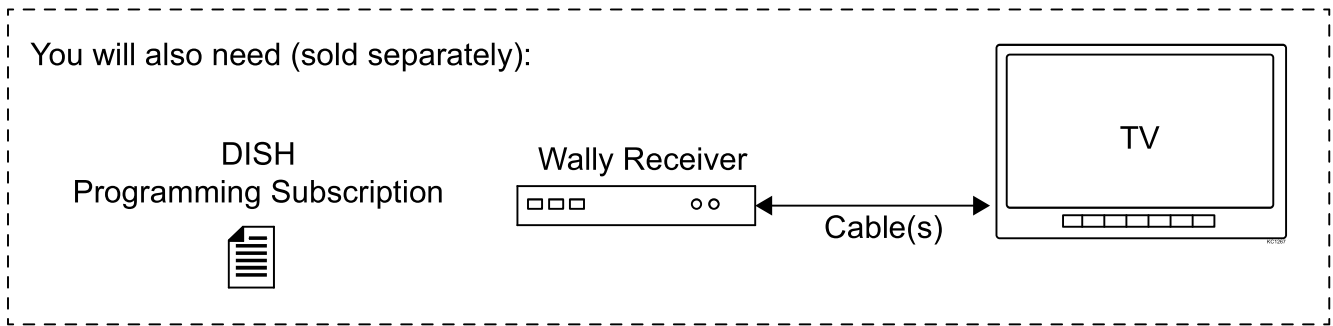
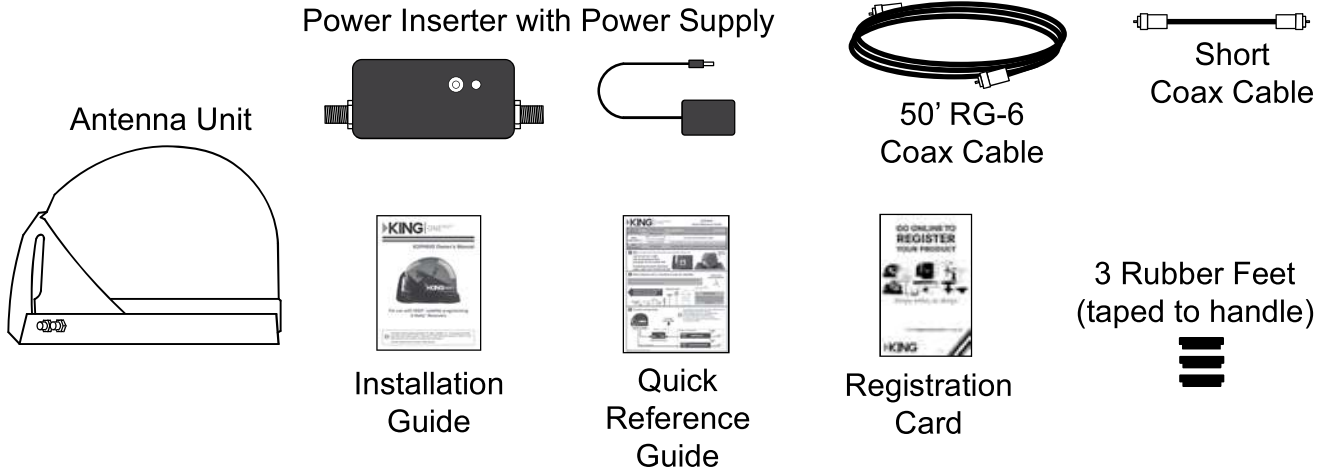

# APPLY RUBBER FEET

**Do not apply rubber feet if roof-mounting the antenna unit. See the included Installation Guide.**

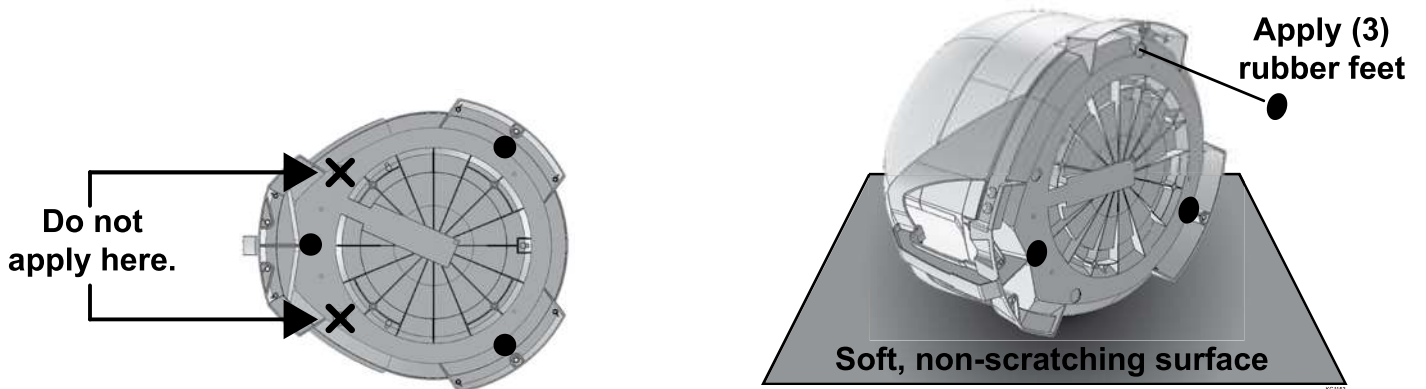

# POSITION ANTENNA



**POSITION THE ANTENNA TO HAVE A CLEAR VIEW OF THE SOUTHERN SKY.**

**ALWAYS KEEP A CLEAR LINE-OF-SIGHT TO THE SATELLITES DURING AND AFTER THE SCAN.**

**SATELLITES IN SOUTHERN SKY**



**OBSTRUCTIONS**

**ANTENNA UNIT**

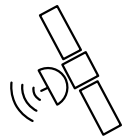
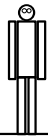
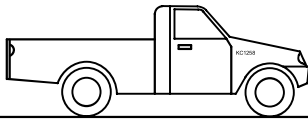

**Reasonably level surface**

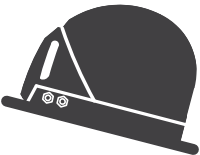
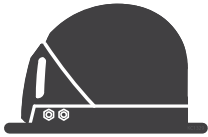

**SATELLITES IN SOUTHERN SKY**

**Clear Line-of-Sight**

**ANTENNA UNIT**

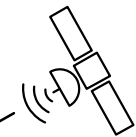
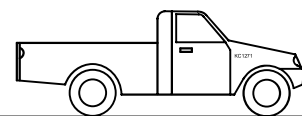
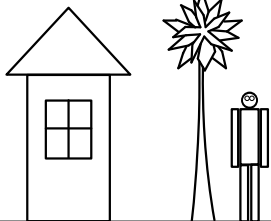

Pointing handle north may speed up scan but is not required.

# OBSERVE CAUTIONS WHEN CONNECTING ANTENNA

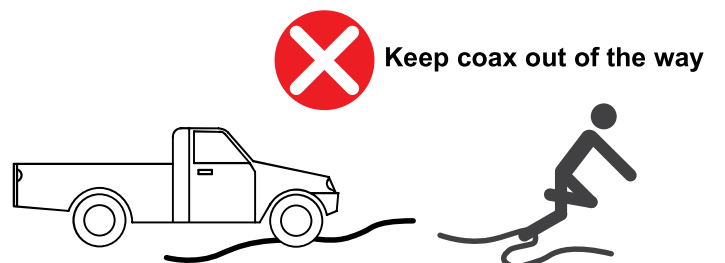
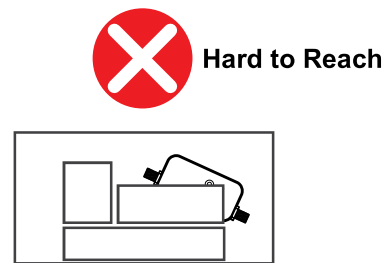
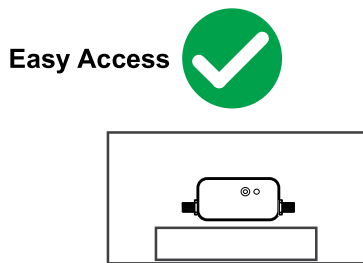
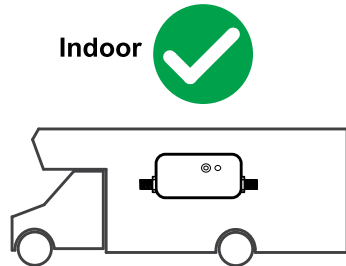
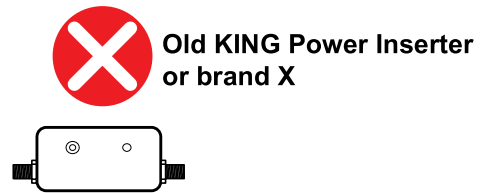
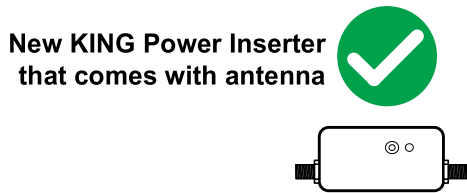
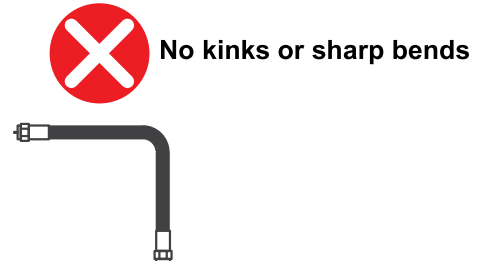
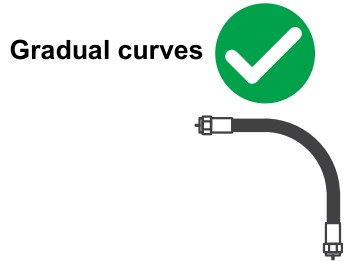
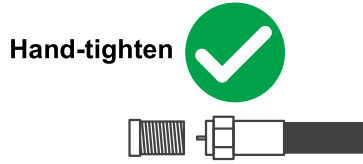

# CONNECT ANTENNA

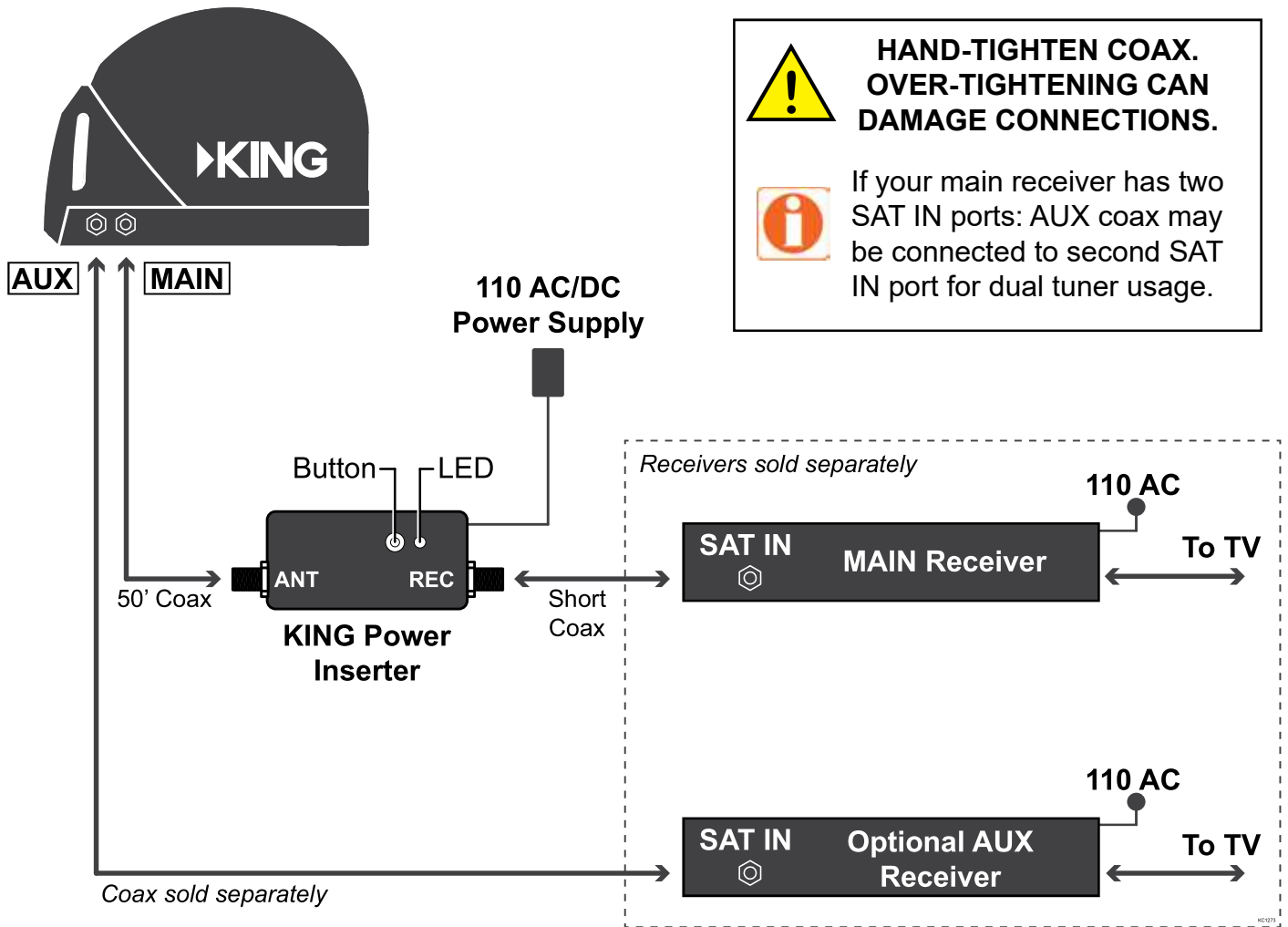

**No kinks or sharp bends!**

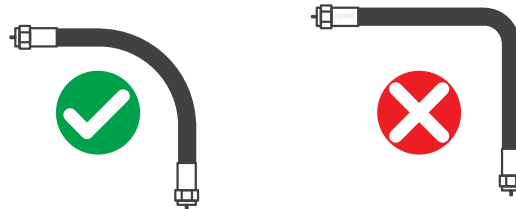

**The antenna unit will detect the Wally receiver and default to the on-screen (TV) instructions. Disregard the LED on the power inserter.**

**Go to page 8 to start a scan.**



This page intentionally left blank.

# SCAN FOR SATELLITES

## NEW AND UNACTIVATED WALLY RECEIVER



**IF YOUR RECEIVER IS NEW AND UNACTIVATED, START HERE.**

**Otherwise go to STANDARD OPERATION on page 14.**

**Your TV screen may look different from what is shown in this manual.  
Screen information may vary depending on choices you make during the setup process.**

**For best results, follow the on-screen instructions.**

1. After connecting and turning on your equipment, the Wally Startup screens will appear (this may take several minutes).



**Make sure your remote has batteries in it.**

2. Follow the on-screen instructions to pair your remote control.

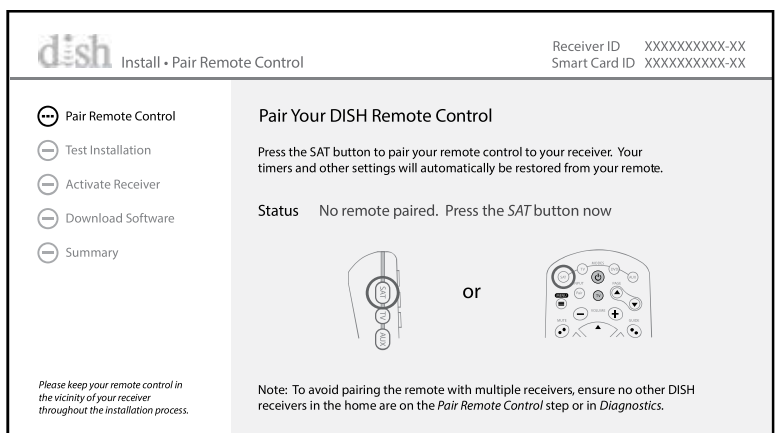

3. Use the arrow buttons on your remote to highlight "Next" and press **Select**.

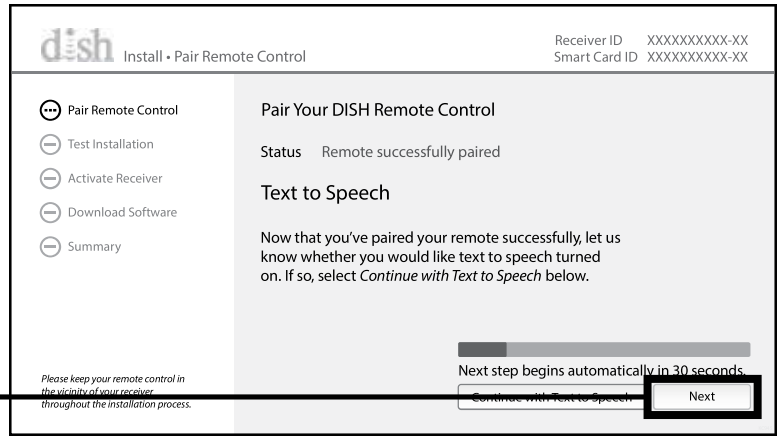

4. Follow the on-screen instructions to select your display resolution.

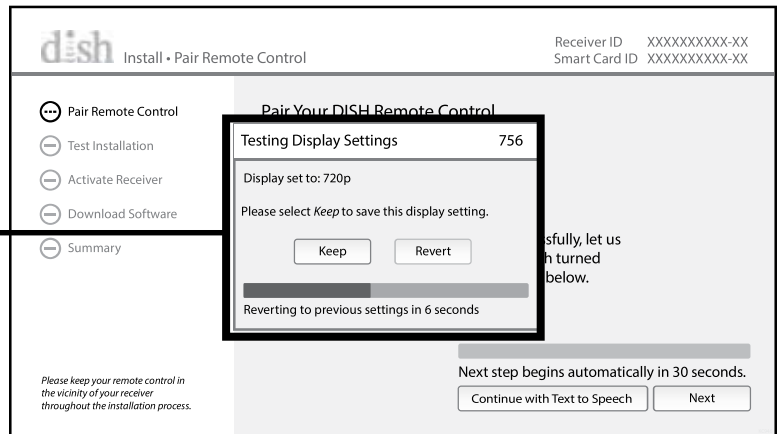

5. The Mobile Antenna Setup screen will appear.

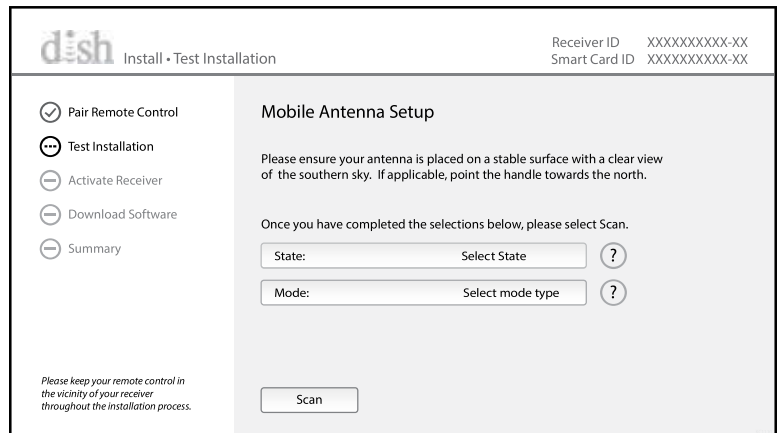

6. Use the arrow buttons on your remote to highlight the state menu. Press **Select** on your remote to open the state menu.

Use the arrow buttons on your remote to highlight the state you are currently in.

Press **Select** on your remote. (State selection will be saved.)

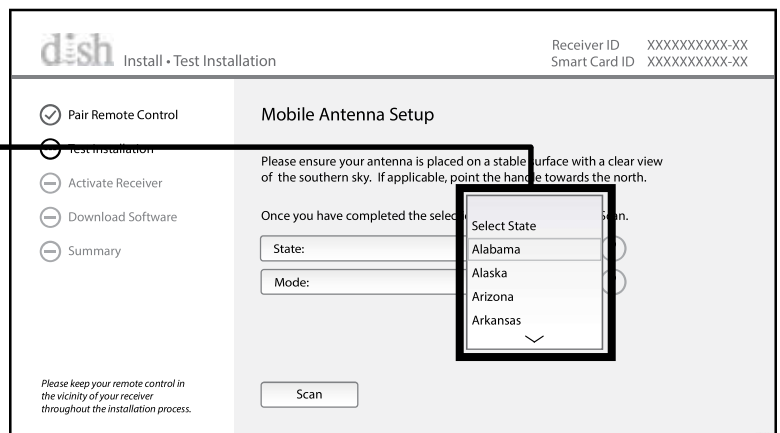

**NOTE FOR STEP 7: The mode menu may not be present on all receivers.**

The 110, 119, 129 trio will work for most of the country.

The antenna unit may have trouble locking onto the 129 when in the northeastern United States (you can use the Dish Diagnostics Screen after a scan to check this).

If the antenna unit does not lock onto the 129, choose the 61.5, 110, 119 trio.

Any programming from the 129 will not be available when using the 61.5, 110, 119 trio.

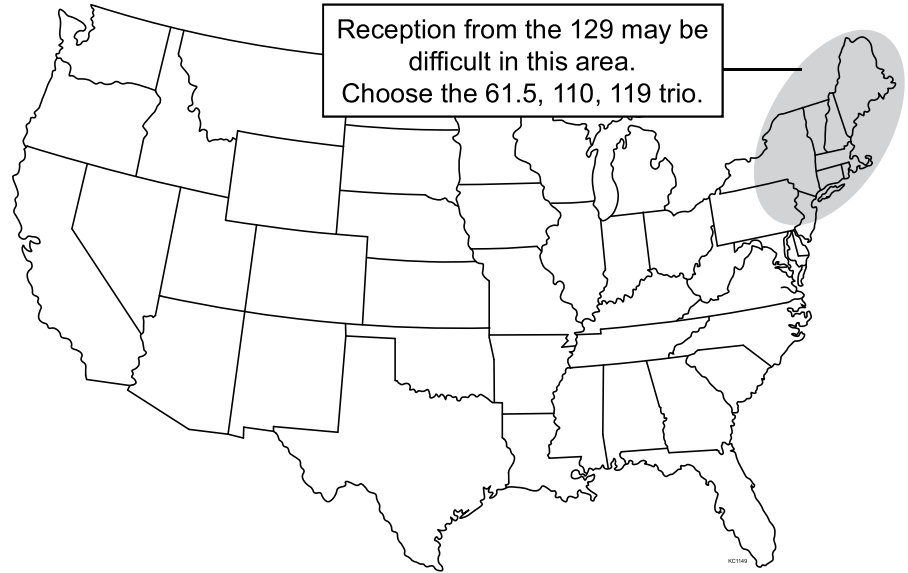

7. Use the arrow buttons on your remote to highlight the mode menu. Press **Select** on your remote to open the mode menu.

Use the arrow buttons on your remote to highlight the mode you wish to select.

Press **Select** on your remote.

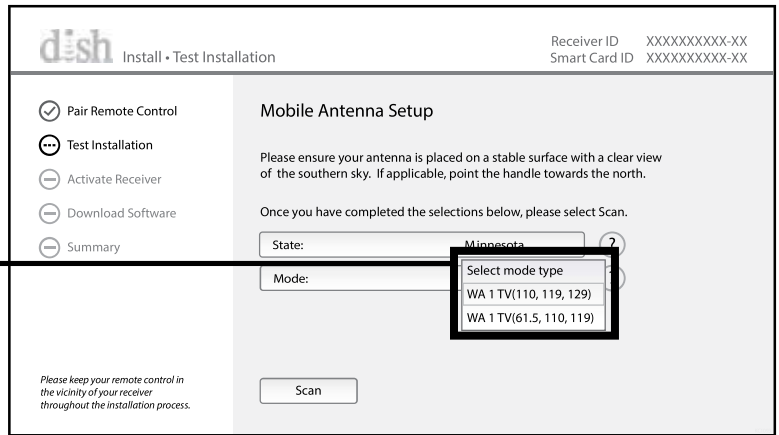

8. Use the arrow buttons to highlight "Scan" and press **Select**.

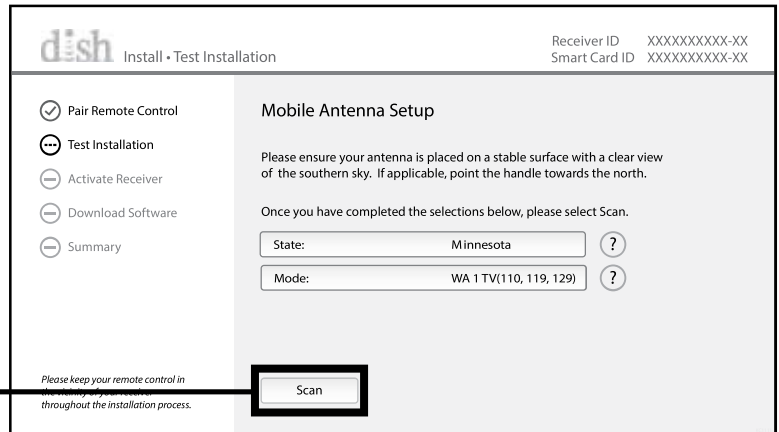

This screen will appear while the antenna scans for satellites.

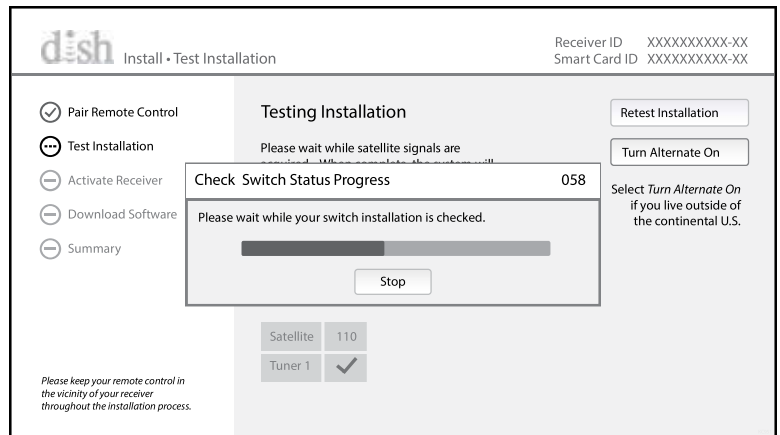

The satellite signals are being acquired. When complete, the system will proceed to the next step automatically.

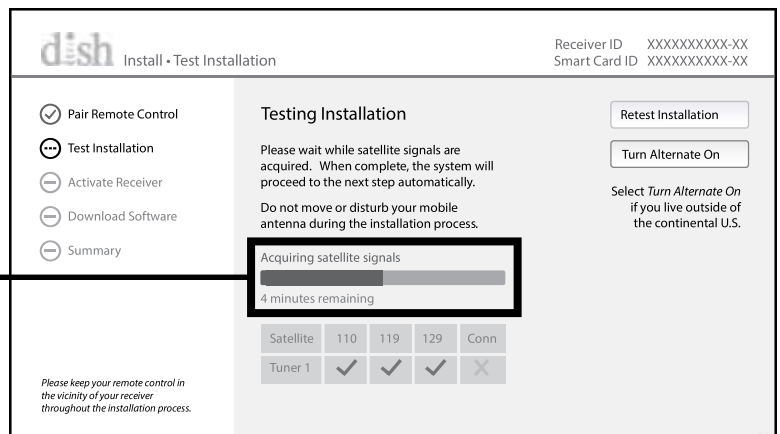

9. You are now ready to activate your receiver. Call a DISH mobile antenna specialist to activate your receiver.

**1-800-963-DISH (3474)**

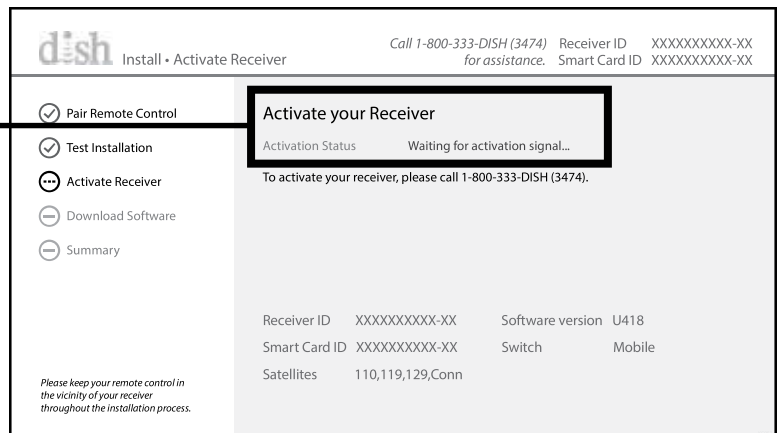

After calling to activate your receiver, a software download will begin.

Do not disturb or unplug your receiver during this process!

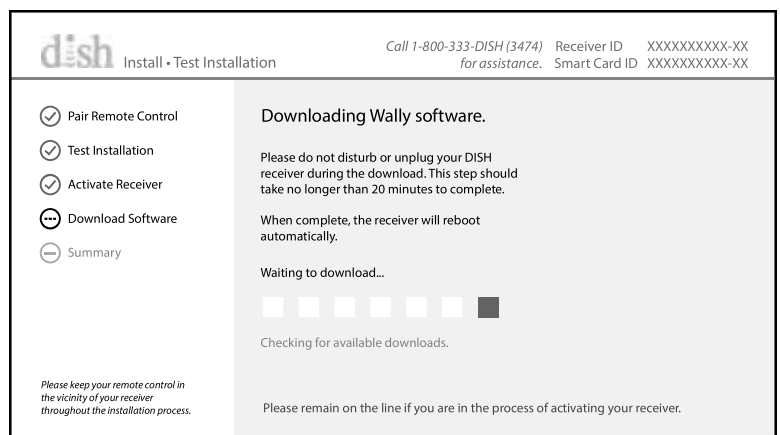

10. When the download is complete, the installation summary will appear.

Use the arrow buttons on your remote to highlight "Activate Receiver" and press **Select**.

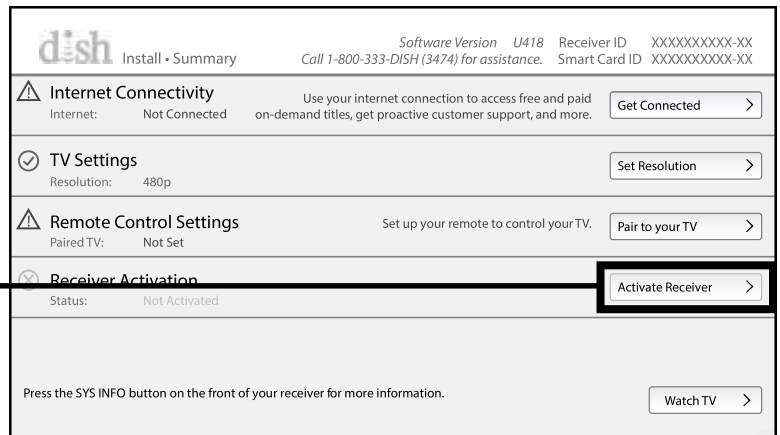

The receiver activates.

This may take a while. PLEASE BE PATIENT.

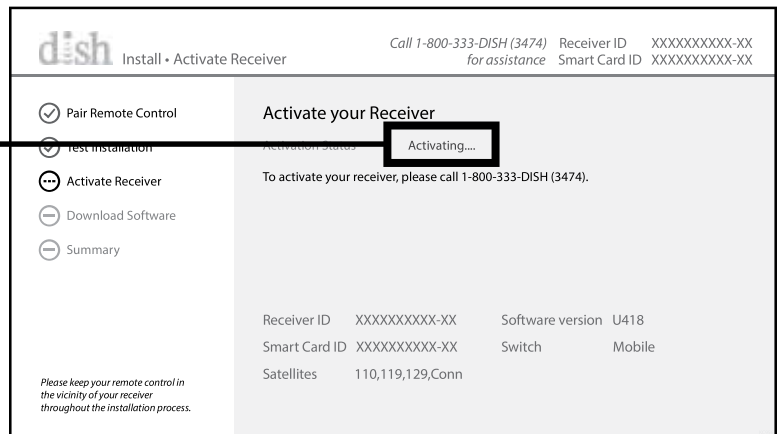

The installation summary screen confirms receiver activation.

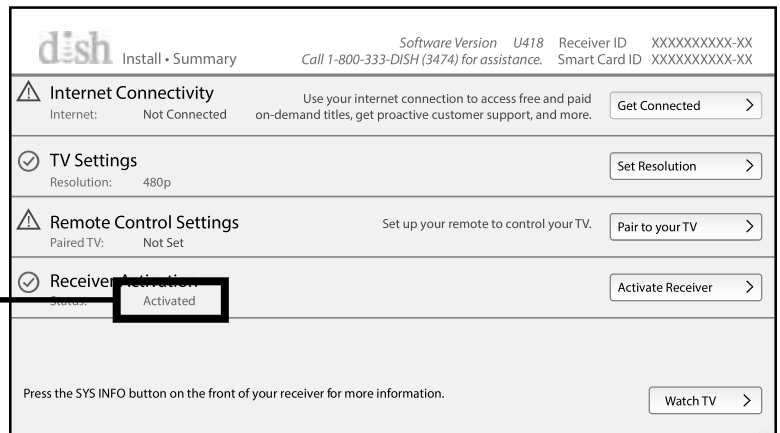

11. Use the arrow buttons on your remote to highlight "Watch TV" and press **Select**.

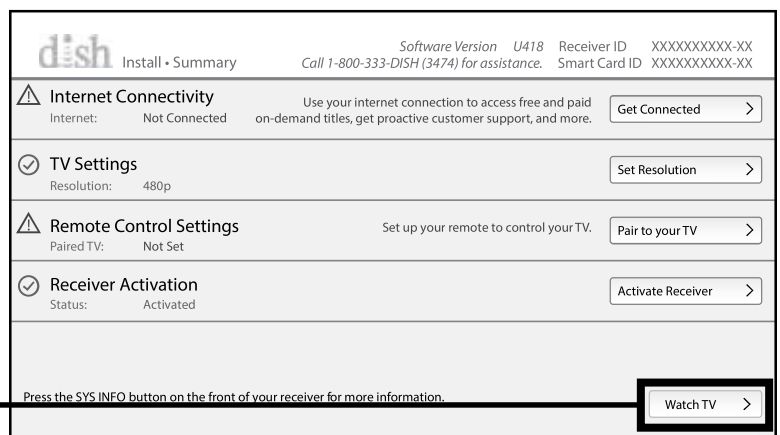

The receiver will acquire signal.

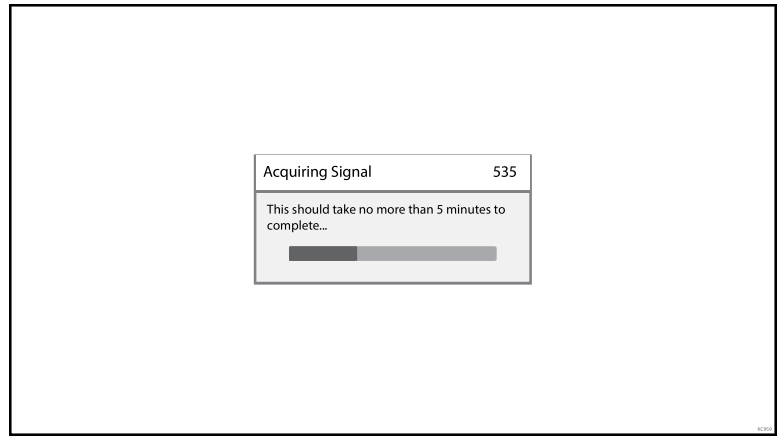

12. Watch TV!



NEW AND UNACTIVATED RECEIVER



Your Wally should have downloaded its program guide already. Check and make sure the full guide is available. If it is not, you will need to reset the Wally for it to download the full guide.

If there is a software update available for your Wally, it will automatically download when you put your Wally in standby mode.

**You can now use STANDARD OPERATION on page 14.**

## STANDARD OPERATION



**IF YOUR RECEIVER IS NEW AND UNACTIVATED, MAKE SURE TO DO THE FIRST-TIME SETUP PROCEDURE ON PAGES 8-13 FIRST.**

**Your TV screen may look different from what is shown in this manual. Screen information may vary depending on choices you make during the setup process.**

**For best results, follow the on-screen instructions.**

1. After connecting and turning on your equipment, the Wally Startup screens will appear (this may take several minutes).

**NOTE:** If the Wally Standby screen appears, press any button on your remote to continue.



2. After the Wally starts up, the Mobile Antenna Setup screen will appear.

**dish** Mobile Antenna Setup

Ensure the mobile antenna is placed on a stable surface with a clear view of the southern sky.

Once you have finished making your selections, select Scan.

Mode: WA 1 TV(61.5, 110, 119) ?

State: Select State ?

Scan

Summary

4 minutes 59 seconds remaining to scan



**NOTE FOR STEP 3: The mode menu may not be present on all receivers.**

The 110, 119, 129 trio will work for most of the country.

The antenna unit may have trouble locking onto the 129 when in the northeastern United States (you can use the Dish Diagnostics Screen after a scan to check this).

If the antenna unit does not lock onto the 129, choose the 61.5, 110, 119 trio.

Any programming from the 129 will not be available when using the 61.5, 110, 119 trio.

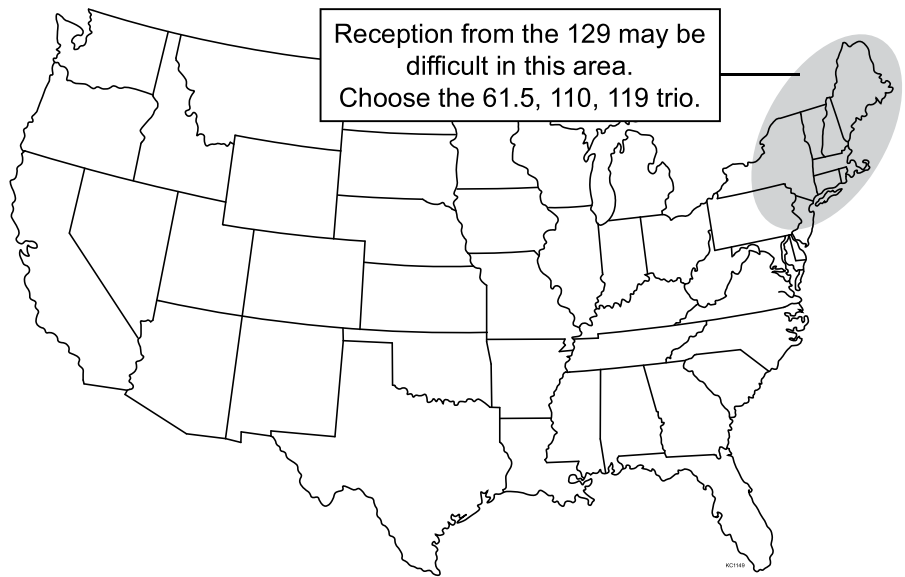

- Use the arrow buttons on your remote to highlight the mode menu. Press **Select** on your remote to open the mode menu.

Use the arrow buttons on your remote to highlight the mode you wish to select.

Press **Select** on your remote.

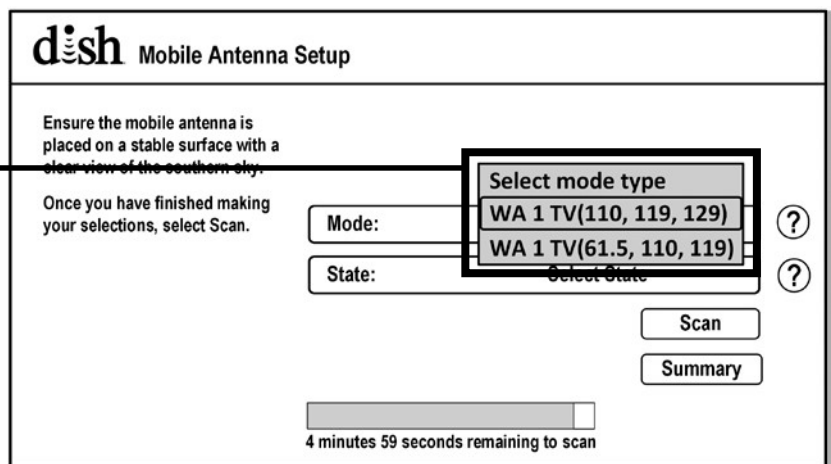

- Use the arrow buttons on your remote to highlight the state menu. Press **Select** on your remote to open the state menu.

Use the arrow buttons on your remote to highlight the state you are currently in.

Press **Select** on your remote. (State selection will be saved.)

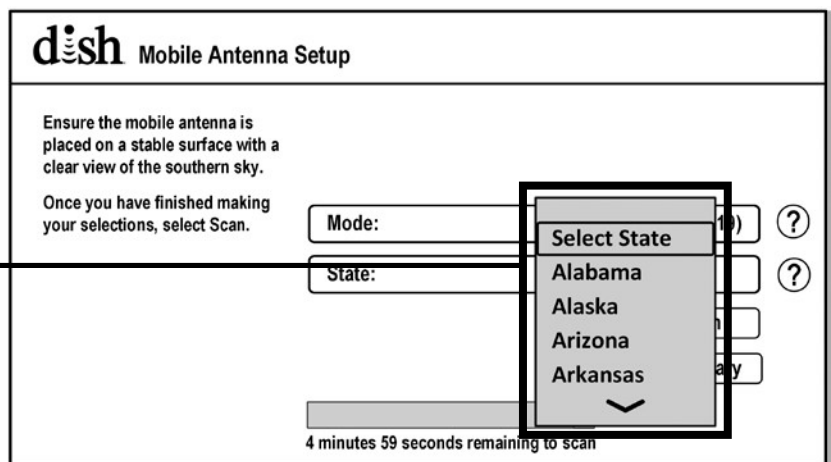

STANDARD OPERATION

- Use the arrow buttons on your remote to highlight "Scan." ●
- Press **Select** on your remote.

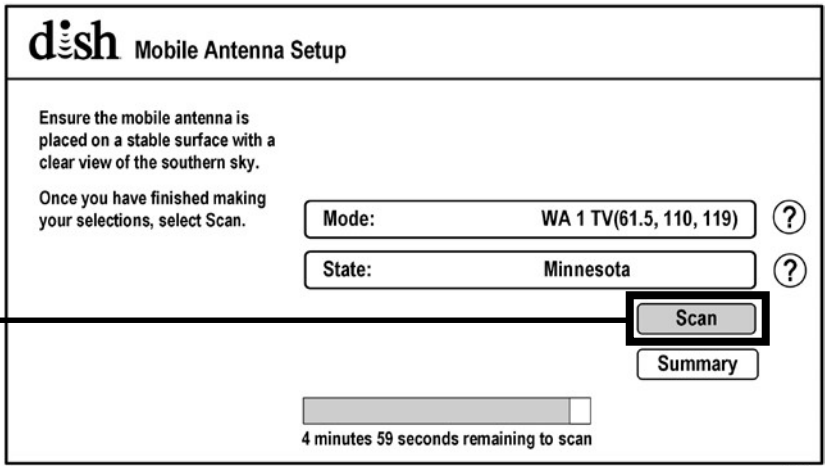

The scan will begin and may take up to several minutes to complete.

This screen will appear during the scan.

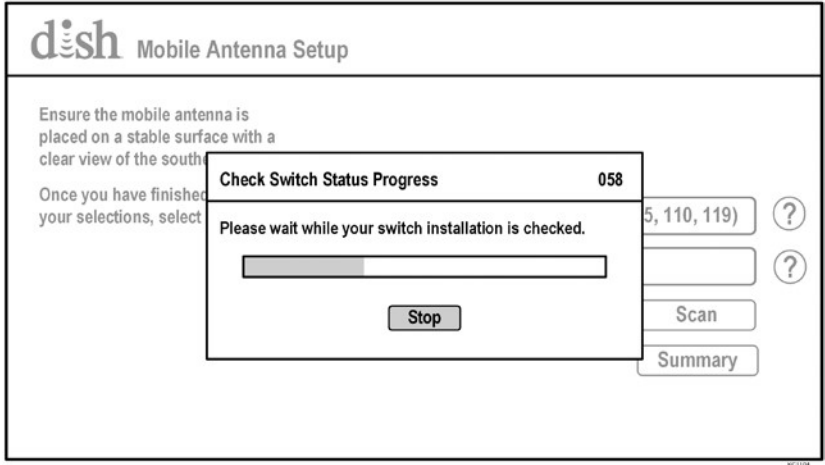

When the scan is complete, the Acquiring Signal screen will appear.

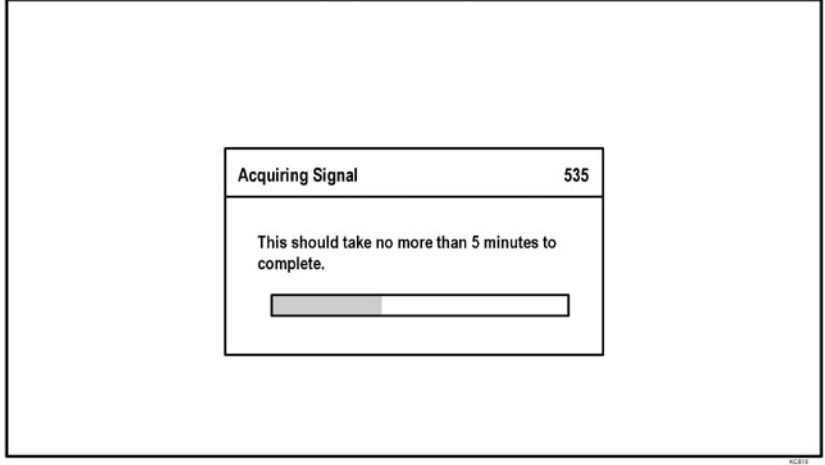

After your receiver has acquired the signal, the program guide will download. This may take up to 10 minutes to complete (potentially longer if an external hard drive is connected).

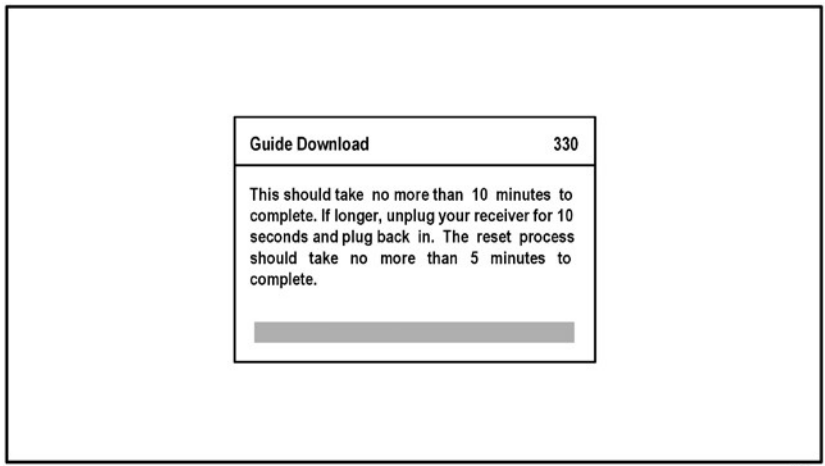

6. When the guide has downloaded, live TV will appear.

Enjoy!



If you move the KING One Pro while in use or after a successful scan, or get a screen indicating complete signal loss, you will have to perform a new scan to restore programming by going to the Mobile Antenna Setup screen as follows:

Press the HOME button to return to the home page. Choose “Settings” and then “Diagnostics.” Choose “Dish 3” and then “Test Installation 5.” This will take you back to the Mobile Antenna Setup screen. Initiate a new scan.

When in the northeastern United States, television programming from the 129 satellite may not be available (see page 15).

If your system is inactive for an extended period of time, you may have to call DISH Customer Service at 1-800-333-DISH (3474) to reauthorize your receiver.

**If your receiver has not been used for a while the 013 error message may appear. Call 1-800-333-DISH (3474) and follow the prompts to reauthorize your receiver. Note that if channel 101 appears, scroll channel up or down to make sure 013 error message does not appear.**

**You can view your programming when your receiver has been authorized and the guide has finished downloading.**

## ENABLE THE ALARM (OPTIONAL)



Use this procedure to enable the alarm.

You can enable or disable the alarm at any time using this procedure.  
See page 25 for an explanation of Modes 1-8.

This antenna is factory preset for MODE 1.

• **DISH Service**

• **Alarm disabled**

To enable the alarm, follow the instructions on page 19 to choose MODE 5.

• **DISH Service**

• **Alarm enabled**

## HOW THE ALARM WORKS

When enabled, the alarm will sound if the coax is disconnected from the antenna.

- Alarm shuts off after 10 seconds or when coax is reconnected.
- Alarm also sounds if coax is disconnected from power inserter.

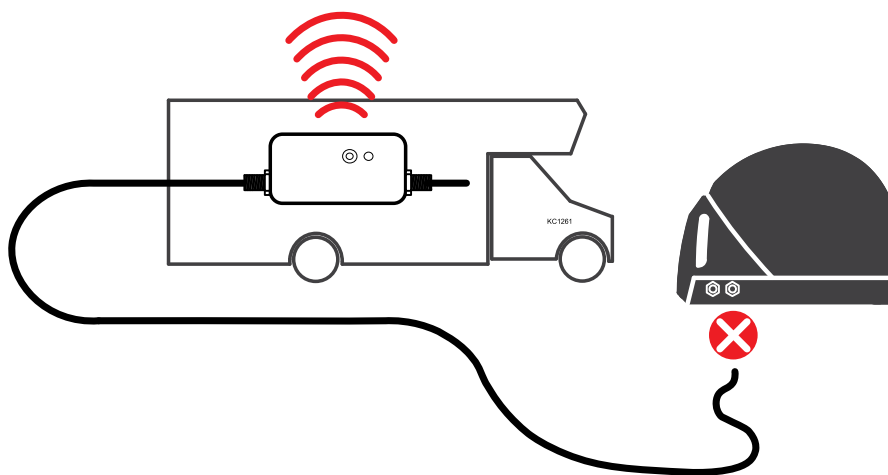

1. Press and hold the power inserter button for 10 flashes of the LED. The LED will flash blue (factory default for new units).
2. Press and release the button repeatedly to choose MODE 5: alarm enabled (the LED will flash blue and white).

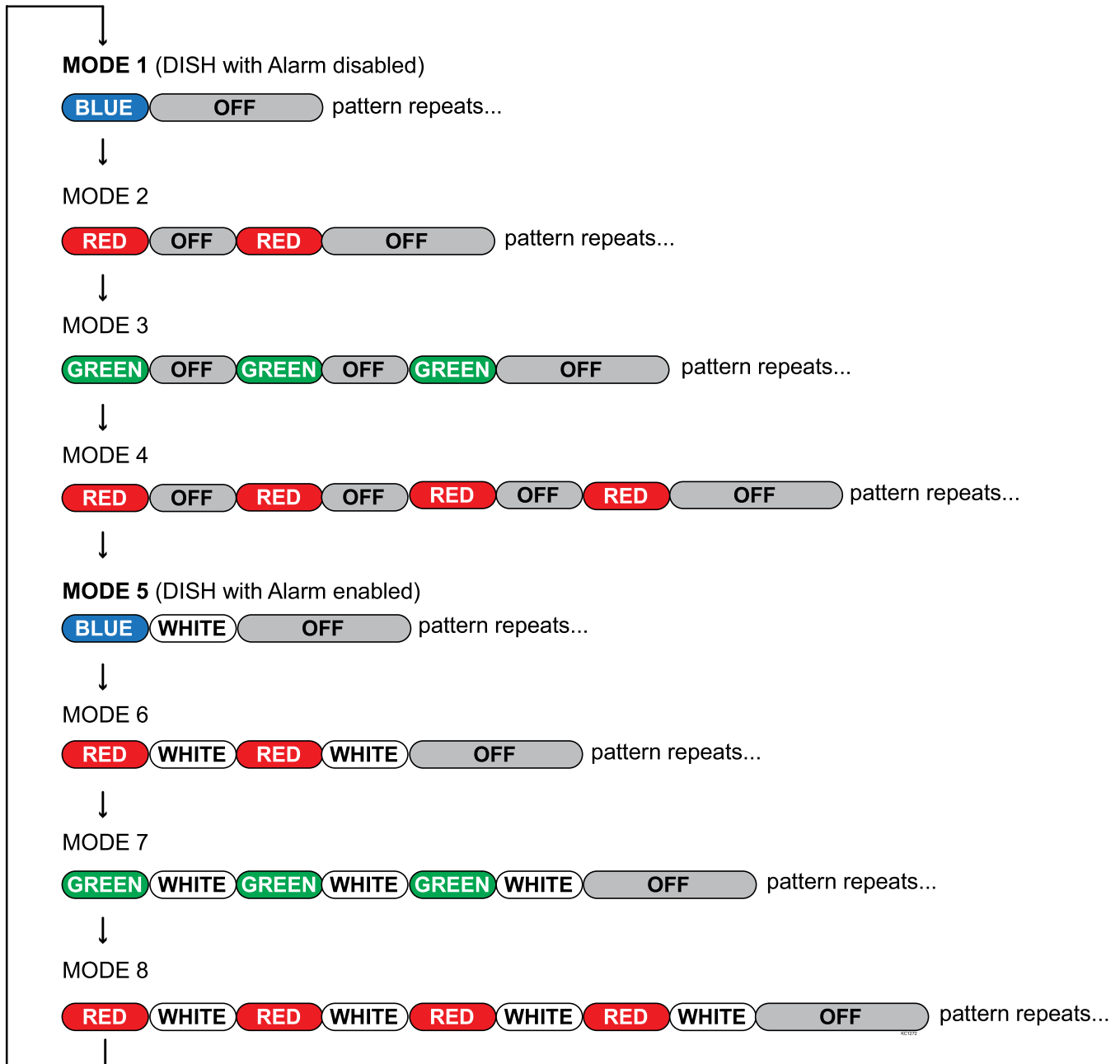

3. When Mode 5 is displayed, press and hold button for about 3 seconds until the LED starts flashing blue.

The alarm is now enabled.



**Time Out Function:** If you do not press the button for one minute after entering configuration mode, the power inserter will stay in whatever mode it was in before you entered configuration mode.

# SECOND RECEIVER OPERATION



If your second receiver is new and unactivated, you must first connect it to the MAIN port and do an initial setup as described in the New and Unactivated Receiver Section.

## INITIAL SETUP FOR SECOND RECEIVER

1. Make sure your second receiver has been properly set up and activated (while connected to the MAIN port) as described in the New and Unactivated Receiver Section (page 8).
2. Connect your properly activated main receiver to the MAIN port.  
Run a scan to lock onto the satellites.
3. Connect the second receiver to the AUX port.
4. Run a check switch test on second receiver.  
When test is complete, save the results.

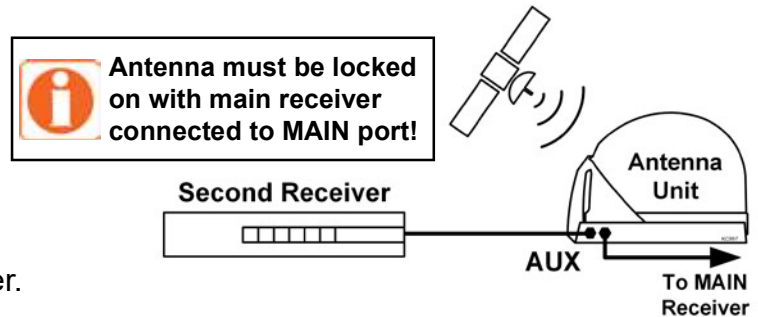

## DOWNLOADING PROGRAMMING TO THE SECOND RECEIVER

5. After completing the check switch test, reset the second receiver by pressing the POWER button on the front panel for 10 seconds. The receiver will reboot and go into sleep mode (green light on front panel will be off). Press **Select** to wake it up.

The receiver will then download the program guide to show only the channels available on the current satellite as determined by the channel selected on the main receiver. Downloading the new program guide can take up to five minutes to complete.

The channels available on the second receiver are determined by the channel/satellite selected on the main receiver. For example, if you select a channel on the main receiver that is broadcast from the 119 satellite, then the second receiver will be able to view any channel broadcast from the 119 satellite.

If you switch channels on the main receiver to one that is broadcast from a different satellite, (for example, your channel was broadcast from satellite 119 but your new channel is broadcast from the 110), the antenna will automatically switch to the 110 satellite and programming will be lost on the second receiver until you either:

- Select a channel on the main receiver that is broadcast from the previous satellite (satellite 119 in this example).
- (or)
- Reset the second receiver by running another check switch test to download the program guide for the newly selected satellite (satellite 110 in this example).



If you choose a channel on the main TV that causes the antenna to switch satellites, you may have to run a check switch on the second receiver.

# ACCESSORIES (Sold separately - see the satellite antenna accessories page at [kingconnect.com](http://kingconnect.com))

## MB700 Quick Release Roof-Mount Kit

Allows you to easily use your KING One Pro as either a roof-mounted or portable antenna.

KING Antenna not included.

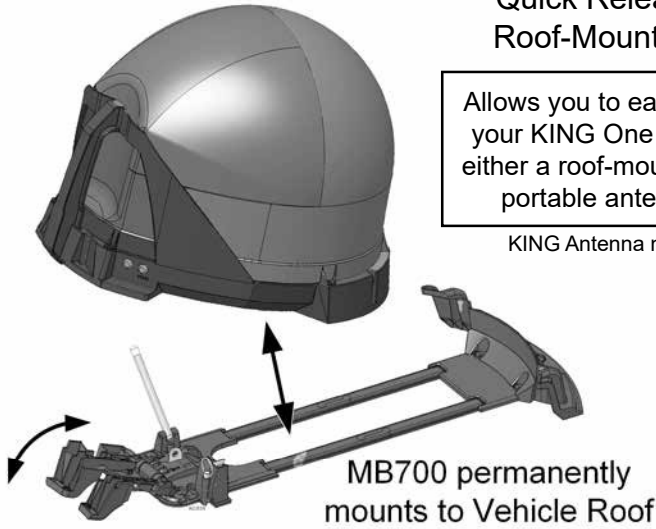

MB700 permanently mounts to Vehicle Roof

## MB500 Mounting Bracket

Includes (2)  
Hanger Brackets



Allows hanging of antenna unit on vehicle window or included hanger bracket.

For stationary use only.  
Vehicle must not be in motion while antenna unit is on window or hanger bracket.

KING Antenna not included.

## CB1000 Carry Bag

KING One Pro fits securely inside. Features include zippered cover, foam padding, carry handles and pockets for cables, receiver and remote.

KING Antenna not included.



## TR1000 Tripod Mount

Allows you to position your KING One Pro almost anywhere for best line-of-sight to satellite. Keeps antenna off the ground away from moisture.

KING Antenna not included.



## MB160 Mounting Bracket



MB160 Mounts to  
Back of Vehicle

The KING One Pro is not compatible with the MB100 Mounting Bracket. Use of the MB100 will void warranty.

The use of any unauthorized mounting bracket will void warranty.

KING Antenna not included.

# SECURE THE ANTENNA

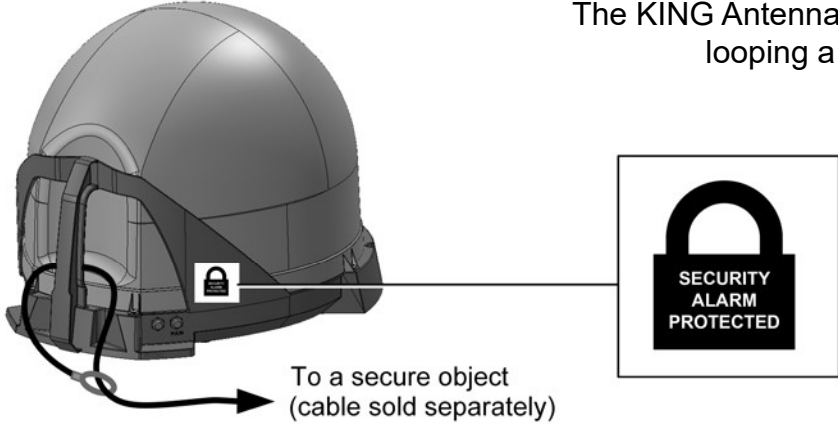

The KING Antenna can be secured to an object by looping a cable thru the handle.

To a secure object (cable sold separately)

If using the security alarm, apply the included sticker for additional theft deterrence.

# TROUBLESHOOTING



If you connect or install the antenna unit using any of the vehicle's internal wiring/coax, and the antenna unit does not work properly, it could be the vehicle's wiring/coax. Connect a known good coax directly from the antenna unit to the power inserter and see if the problem goes away. If it does, the vehicle's wiring/coax is at fault. KING is not responsible for faulty vehicle wiring/coax.

Symptom	Possible Cause	Troubleshooting
Antenna unit does not scan for satellites.	No power to antenna unit.	Make sure antenna unit is connected to power inserter.  Make sure power supply is plugged into a known good power source and connected to power inserter.
Antenna unit scans but no picture on TV.	Improper connections made.	Make sure antenna unit is connected to power inserter, and power inserter is plugged in.  Make sure powered receiver is connected to TV and the power inserter.
Antenna unit scans but does not find satellite.	Line of sight obstruction.	Move antenna unit to have a clear view of the southern sky. Start a new scan.
Picture on TV goes in and out.	Temporary obstruction of signal.	Heavy rain or snow may cause loss of signal. Reception will improve as weather clears.  Make sure nothing is temporarily blocking view to the southern sky (like tree branches blowing in the wind).



## WALLY RECEIVERS

Symptom/Message	Possible Cause	Troubleshooting
"SmartCard Not Inserted" message (021) on startup.	SmartCard is not fully seated in Wally slot.	Your SmartCard is located on the left side of the Wally. Pull out the SmartCard and insert it back into the slot. Make sure the arrow on the SmartCard is facing up and is inserted first into the receiver. If there is not a SmartCard in your receiver please call 1-800-333-DISH.
My remote is not working.	Remote is in wrong mode.	If you think the remote is paired, but in the wrong mode, press the "SAT" button on the left side of the remote.
	Your batteries may need to be replaced.	Check to make sure the batteries are properly inserted in your remote. If "SAT" on the front top of the remote does not light up when you press the SAT button on the left side of the remote, replace the batteries.
	Your remote is not currently paired with your receiver.	To pair your remote, press the "SYS INFO" button on the front of the Wally and then press the "SAT" button on the left side of your remote.
Complete Signal Loss - 015A	Obstructions to the KING One Pro's view of the southern sky, such as tree branches, severe rain, etc.	Make sure nothing is blocking the KING One Pro's view of the southern sky, such as tree branches, severe rain, or other obstructions.
	Coax cable not connected properly between your Wally and the KING One Pro.	Check that the coax cable between your Wally and the KING One Pro is connected properly and hand-tightened.
	You have selected a local channel but are outside of its spot beam area.	First, verify you have reception by selecting a nationally broadcast channel (CNN, ESPN, etc.).  Then call DISH at 1-800-333-DISH to have your locals switched to your current area.
	KING One Pro has been moved.	If KING One Pro has been moved, initiate a new scan.
Channel Signal Loss - 004	KING One Pro has not tracked to the appropriate orbital slot upon channel change.	There may be an obstruction blocking signal from the newly chosen satellite.  Verify there are no obstructions, or move KING One Pro to have a better view of southern sky and initiate a new scan. Once your system has found its satellites, it may take a few minutes to download the electronic program guide and acquire signal before live TV appears.

Symptom/Message	Possible Cause	Troubleshooting
All Satellites Not Found - 150	Obstructions to the KING One Pro's view of the southern sky, such as tree branches, severe rain, etc.	Make sure nothing is blocking the KING One Pro's view of the southern sky, such as tree branches, severe rain, or other obstructions.
	Your physical location may be outside the footprint of the desired orbital slot.	Unplug the power cord of your receiver for 10 seconds and plug it back in. It may take up to 5 minutes for your receiver to power back on.
No Satellites Found - 151	Obstructions to the KING One Pro's view of the southern sky, such as tree branches, severe rain, etc.	Make sure nothing is blocking the KING One Pro's view of the southern sky, such as tree branches, severe rain, or other obstructions.
	Coax cable not connected properly between your receiver and the KING One Pro.	Check that the coax cable between your receiver and the KING One Pro is connected properly and hand-tightened.  Unplug the power cord of your receiver for 10 seconds and plug it back in. It may take up to 5 minutes for your receiver to power back on.
OTA Channel Signal Lost - 739	The signal has been lost for this over-the-air channel. This can be due to relocation or realignment of the antenna.	Reposition antenna into optimal position to get clearest signal. May need to scan again for OTA channels.
	Possible obstruction of the signal.	Remove obstruction from signal path.
OTA Tuner Module Not Detected - 978	An over-the-air (OTA) tuner module has been removed.	Reinstall OTA tuner module. When this is complete the Wally will request to be reset. Select YES to reset the Wally.
Local Channels Interrupted - 536		Call DISH at 1-800-333-DISH to have your locals switched to your current area.
Missing Channels.	The electronic program guide may not be set to "My Channels."	Press the GUIDE button on your remote twice to display the "Favorite Channels" menu. Select "None" or one of your favorite channels list.
	You may not have the orbital slots required to view the missing television programming.	Confirm that you subscribe to the missing channel by using <a href="http://dish.com/mychannels">dish.com/mychannels</a> .
Low signal strength.	Because of the small size of the highly portable KING One Pro, signal strength may not be as strong as with a fixed home antenna.	N/A

Symptom/Message	Possible Cause	Troubleshooting
Unable to Access Feature - 024	Feature not downloadable.	Keep receiver in standby for 1 hour.
Sporting Event Blackout - 744	Blackout patterns are applied based on the physical address on your account. Events outside the area surrounding your physical address may not be available.	N/A
Outside of Viewing Area - 120	You are outside of the viewing area of currently available channels.	Call DISH at 1-800-333-DISH to have your locals switched to your current area.

## MODE CHART

MODE	SERVICE	SATELLITES		ALARM
1	DIRECTV	101, 119	DIRECTV Subscribers	DISABLED
	DISH	61.5, 110, 119, 129	DISH subscribers with Wally, ViP211z, 211k, 211 or 411 receivers	
2	DISH	110, 119, 129	DISH subscribers with receivers not listed in MODE 1	DISABLED
3	Bell TV	82, 91	Bell TV Subscribers	DISABLED
4	DISH	61.5, 110, 119	DISH subscribers with receivers not listed in MODE 1	DISABLED
5	DIRECTV	101, 119	DIRECTV Subscribers	ENABLED
	DISH	61.5, 110, 119, 129	DISH subscribers with Wally, ViP211z, 211k, 211 or 411 receivers	
6	DISH	110, 119, 129	DISH subscribers with receivers not listed in MODE 1	ENABLED
7	Bell TV	82, 91	Bell TV Subscribers	ENABLED
8	DISH	61.5, 110, 119	DISH subscribers with receivers not listed in MODE 1	ENABLED



**MODES 1 & 5:** Antenna unit will detect either DIRECTV or DISH receiver and function accordingly.

# LIMITED WARRANTY

KING One Pro Satellite Antennas are thoroughly inspected and tested before leaving the factory, and are covered by the following limited warranty from the date of original purchase:

- Two-year parts warranty: The customer is not responsible for the cost of replacement parts if the original part is determined to be defective under the terms of the warranty. The customer is responsible for the cost of replacement parts after two years.
- One-year labor warranty: The customer is not responsible for labor costs to repair unit if labor is performed within the labor warranty period. The customer is responsible for all labor costs after one year.

Only KING and certified dealers may perform warranty evaluations and repairs. Depending upon the problem, KING may authorize a dealer to perform the necessary repairs. Any warranty labor outside of that performed at the factory is not covered unless 1) the product has been installed by an authorized dealer/installer or OEM manufacturer and 2) the dealer/installer receives prior authorization to perform the repair.

A certified dealer must not perform any repair without first contacting KING for a Service Order Number. KING will advise the dealer on how to proceed with any repairs.

Should any trouble develop during the warranty period, contact KING at (952) 345-8147. You must contact KING before the warranty period expires. The customer must supply proof of purchase (such as a dated sales receipt) when requesting warranty service. If the customer cannot supply proof of purchase, warranty period shall start 30 days after date of manufacture.

If it is determined that the unit needs to be returned to KING, customer must return COMPLETE product, freight prepaid, to: **KING, 11200 Hampshire Avenue South, Bloomington, MN 55438-2453.**

If inspection shows the trouble is caused by defective workmanship or material, KING will repair (or at its option, replace) without charge.

When returning product, KING will supply an RMA number (Return Merchandise Authorization). This number must be clearly written on the box. Failure to clearly write RMA number on box may result in delays in processing claim. Along with product, customer should include in the box: his/her name, address, daytime phone number, proof of purchase and description of the problem.

This warranty does not cover installation and external wiring, or remanufactured units. This warranty does not cover damage caused by the use of an accessory other than a KING accessory designed for the product. This warranty is not transferable from the original owner.

Due to the expanding and changing TV market, KING cannot be held responsible for changes made to satellite services. Software updates to address such issues are not covered under warranty.

This warranty also does not apply where:

- The product has been abused, misused, improperly installed or improperly maintained.
- The product has been used with an accessory other than a KING accessory designed for the product.
- Repairs have been made or attempted by others that are not certified by KING to do such repairs.
- Repairs are required because of normal wear and tear.
- Alterations have been made to the product.
- The product or any associated component has been opened without authorization or disassembled to any degree.
- Damage has been caused by power washing.
- Circumstances beyond the control of KING cause the product to no longer operate correctly.
- Customer is not the original owner.

In no event shall KING be liable for any indirect, incidental, or consequential damages from the sale or use of the product. This disclaimer applies both during and after the term of this warranty.

KING disclaims liability for any implied warranties, including implied warranties of "merchantability" and "fitness for a specific purpose," after the term of this warranty.

This warranty gives you specific legal rights, and you may also have other rights, which vary from state to state. Some states do not allow the exclusion or limitation of incidental or consequential damages, so the above limitation or exclusion may not apply to you. Some states do not allow limitations on how long an implied warranty lasts, so the above limitation may not apply to you.

# FCC GUIDELINES

This equipment has been tested and found to comply with the limits for a Class B digital device, pursuant to part 15 of the FCC Rules. These limits are designed to provide reasonable protection against harmful interference in a residential installation. This equipment generates, uses and can radiate radio frequency energy and, if not installed and used in accordance with the instructions, may cause harmful interference to radio communications. However, there is no guarantee that interference will not incur in a particular installation. If this equipment does cause harmful interference to radio or television reception, which can be determined by turning the equipment off and on, the user is encouraged to try to correct the interference by one or more of the following measures:

- Reorient or relocate the receiving antenna.
- Increase the separation between the equipment and the receiver.
- Connect the equipment into an outlet on a circuit different from that to which the receiver is connected.
- Consult the dealer or an experienced radio/TV technician for help.

## NOTES:



**Simply better, by design.™**



---

11200 Hampshire Avenue South, Bloomington, MN 55438  
PH 952.922.6889 || FAX 952.922.8424 || [kingconnect.com](http://kingconnect.com)

©2021 KING

23433 Rev C

All trademarks are the sole property of their respective owners.