

INSTALLATION AND OPERATION MANUAL



DIRECT VENT GAS WATER HEATER



MODELS
SW6D • SW6DE • SW6DM • SW6DEM

FOR INSTALLATION IN RECREATIONAL VEHICLES AND MOBILE HOUSING

FOR YOUR SAFETY

WHAT TO DO IF YOU SMELL GAS

- DO NOT TRY TO LIGHT ANY APPLIANCE.
- DO NOT TOUCH ANY ELECTRIC SWITCH: DO NOT USE ANY PHONE IN YOUR VEHICLE.
- IMMEDIATELY CALL YOUR GAS SUPPLIER FROM A NEIGHBOR'S PHONE. FOLLOW THE GAS SUPPLIER'S INSTRUCTIONS.
- IF YOU CANNOT REACH YOUR GAS SUPPLIER, CALL THE FIRE DEPARTMENT.

FREEZE WARNING

DRAIN HEATER IF SUBJECT TO FREEZING TEMPERATURES.

WARNING: IMPROPER INSTALLATION, ADJUSTMENT, ALTERATION, SERVICE OR MAINTENANCE CAN CAUSE INJURY OR PROPERTY DAMAGE. REFER TO THIS MANUAL. FOR ASSISTANCE OR ADDITIONAL INFORMATION, CONSULT A QUALIFIED INSTALLER, SERVICE AGENCY OR THE GAS SUPPLIER.

FOR YOUR SAFETY

DO NOT STORE OR USE GASOLINE OR OTHER COMBUSTIBLE MATERIALS OR LIQUIDS NEAR OR ADJACENT TO THIS HEATER OR ANY OTHER APPLIANCE. THIS APPLIANCE SHALL NOT BE INSTALLED IN ANY LOCATION WHERE FLAMMABLE LIQUIDS OR VAPORS ARE LIKELY TO BE PRESENT.

AN ODORANT IS ADDED TO THE GAS USED BY THIS WATER HEATER.

INSTALLER: AFFIX THESE INSTRUCTIONS TO OR ADJACENT TO WATER HEATER.

OWNER: RETAIN THESE INSTRUCTIONS AND WARRANTY FOR FUTURE REFERENCE.

ALL TECHNICAL AND WARRANTY QUESTIONS SHOULD BE DIRECTED TO THE COMPANY LISTED ON THE WARRANTY, OR RATING PLATE WHICH CAME WITH YOUR WATER HEATER.



Suburban
Manufacturing Company

a division of AIRXCEL, Inc.

SUBURBAN MANUFACTURING COMPANY
676 Broadway Street
Dayton, Tennessee 37321
423-775-2131
Fax: 423-775-7015

INSTALLATION REQUIREMENTS

WARNING! Installation of this appliance must be made in accordance with the written instructions provided in this manual. No agent, representative or employee of Suburban or other person has the authority to change, modify or waive any provision of the instructions contained in this manual.

CAUTION: If possible, do not install the water heater to where the vent can be covered or obstructed when any door on the trailer is opened. If this is not possible, then the travel of the door must be restricted in order to provide a 6" minimum clearance between the water heater vent and any door whenever the door is opened.

CAUTION: Due to the differences in vinyl siding, this appliance should not be installed on vinyl siding without first consulting with the manufacturer of the siding or cutting the siding away from the area around the appliance vent.

CAUTION: In any installation in which the vent of this appliance can be covered due to the construction of the RV or some special feature of the RV such as slide out, pop-up etc., always insure that the appliance cannot be operated by setting the thermostat to the positive "OFF" position and shutting off all electrical and gas supply to the appliance.

CAUTION: Do not install this appliance to where the vent terminates below a slide-out. This appliance is not to be installed under any overhang. It must be free and clear of any type overhang.

This installation must conform with the requirements of the authority having jurisdiction or in the absence of such requirements with the latest edition of the National Fuel Gas Code ANSI Z223.1; and the latest edition of the American National Standard for Recreational Vehicles-501C. In Canada the installation should conform with the following standards.

A. For installation in Recreational Vehicle

1. Gas - CSA standard CSA Z240.4.2 Installation Requirements for Propane Appliances and Equipment in Recreations Vehicles.
2. Electrical - CSA standard C22.2 No. 148/Z240.6.2 Electrical Requirements for Recreational Vehicles.
3. Plumbing - CSA standard CSA Z240.3.2 Plumbing Requirements for Recreational Vehicles.

B. For installation in Mobile Housing

1. Gas - CSA standard CSA Z240.4.1 Installation Requirements for Gas Burning Appliances and Equipment in Mobile Homes.
2. Electrical - CSA standard CSA C22.1 Canadian Electrical Code Part 1.
3. Plumbing - CSA standard CSA Z240.3.1 Plumbing Requirements for Mobile Homes.

The appliance shall be disconnected from the gas supply piping system during any pressure testing of the system.

The appliance and its gas connections shall be leak tested before placing the appliance in operation.

All air for combustion must be supplied from outside the structure. Air for combustion must not be supplied from occupied spaces.

INSTALLATION INSTRUCTIONS

Minimum clearance from combustible construction on sides, top, floor and rear = 0 inches. Provide room for access to rear of heater for servicing.

Provide an opening flush with floor in outer wall of coach as shown. Wall of coach should be framed as shown in Figure 1. Maintain inside dimensions listed below. Do not install on carpet unless the carpet is covered by a metal or wood shield covering the entire area underneath the water heater. If you prefer, you may cut away the carpet from this area.

INSTALLATION USING FLUSH MOUNT FRAME & DOOR (See Figure 2 for Illustration)

A. Position heater into framed opening as illustrated. Slide unit into opening until the front of the control housing is flush with the exterior coach skin.

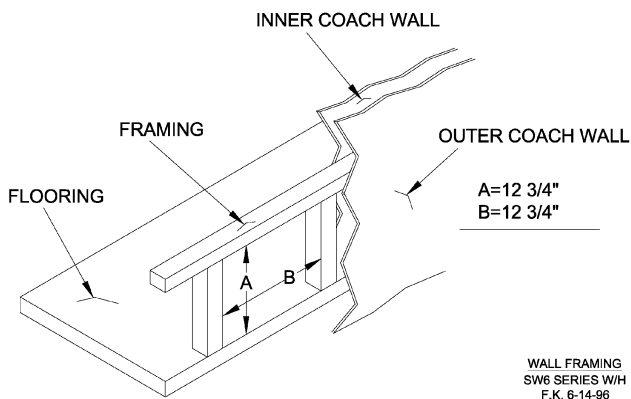

Figure 1

B. Secure the control housing to the coach wall (framed opening) at the top and sides of control housing compartment using screws or other suitable fasteners. Recess the screws or fasteners back far enough from the front edge of control housing (approximately 1 1/2") in order to clear the flange on door frame. The door frame, when installed, must not overlap onto screw or other fastener head. If due to the wall thickness, it is not possible to secure the water heater without covering the fastener head with the door frame, it is important to not over tighten the fastener and distort the control housing. Over tightening of the fastener may cause water heater leaks between the control housing and the door frame.

NOTE: Caulk around screw or fastener heads to assure water tight seal.

C. Install chocks, one on each side of water heater, as illustrated in Figure 1A.

D. On mesa or yoder type sidewalls, flatten the wall area around the opening.

E. Caulk around framed opening (trailer skin) as illustrated.

F. Caulk around door frame using 2 beads of silicone caulking (or suitable caulking) - one on flange to seal to control housing and one around back side of frame to seal to coach skin. (See detail A in illustration.)

G. Insert door frame into control housing and secure with three (3) No. 8-15 x 3 1/2" screws provided.

H. To install door, place the two holes in the bottom of the door over the door pins on the frame. Close the door so that the latch protrudes through the slot in the door. Turn latch 90 degrees to fasten door.

I. The module board on models SW6D and SW6DE is not secured to the water heater. It is to be permanently mounted by the installer.

The module board must be mounted to where it is accessible for service yet out of way of children. It should be located in a place where it cannot be subjected to moisture, cleaning chemicals, flammable vapors and liquids, etc.

The board and all wiring to the board must be protected in order to prevent damages and accidental contact with these parts. The module board may be mounted with two (2) No. 6 x 5/8 screws or other suitable hardware.

INSTALLATION USING HINGED DOOR

(See Figure 3 for illustration)

A. Position heater into framed opening as illustrated.

B. On mesa or yoder type sidewalls, flatten the wall area around the opening.

C. Caulk around framed opening (trailer skin) as illustrated.

D. Lay a bead of silicone caulking (or suitable caulking) around the inner edge of the control housing (top, bottom and sides). See detail "A" in illustration. This will seal frame to control housing.

E. Apply a bead of silicone caulking (or suitable caulking) around back side of door frame. See detail "A" in illustration. This will seal frame to coach skin.

F. Fit the door frame into control housing (over the caulking already applied) and pull frame tight to control housing using the three (3) No. 8-15 x 3 1/2" screws provided.

G. Push water heater into framed opening until back side of door frame (now attached to control housing) is against the side of the coach and firmly attach with screws around the perimeter of the frame. NOTE: The two (2) holes in bottom of frame identified as "A" in Figure 3 are also used to mount door hinge to the frame.

H. Install chocks, one on each side of water heater, as illustrated in Figure 1A.

I. Attach door to frame as illustrated.

J. Close the door so that the door latch protrudes through the slot in the door. Turn latch 90 degrees to fasten door.

K. The module board on models SW6D and SW6DE is not secured to the water heater. It is to be permanently mounted by the installer.

The module board must be mounted to where it is accessible for service yet out of way of children. It should be located in a place where it cannot be subjected to moisture, cleaning chemicals, flammable vapors and liquids, etc.

The board and all wiring to the board must be protected in order to prevent damages and accidental contact with these parts. The module board may be mounted with two (2) No. 6 x 5/8 screws or other suitable hardware.

WATER HEATER AS VIEWED FROM INSIDE R. V.

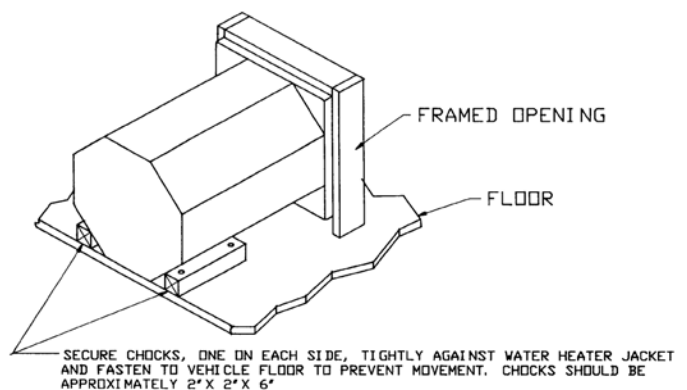

Figure 1A

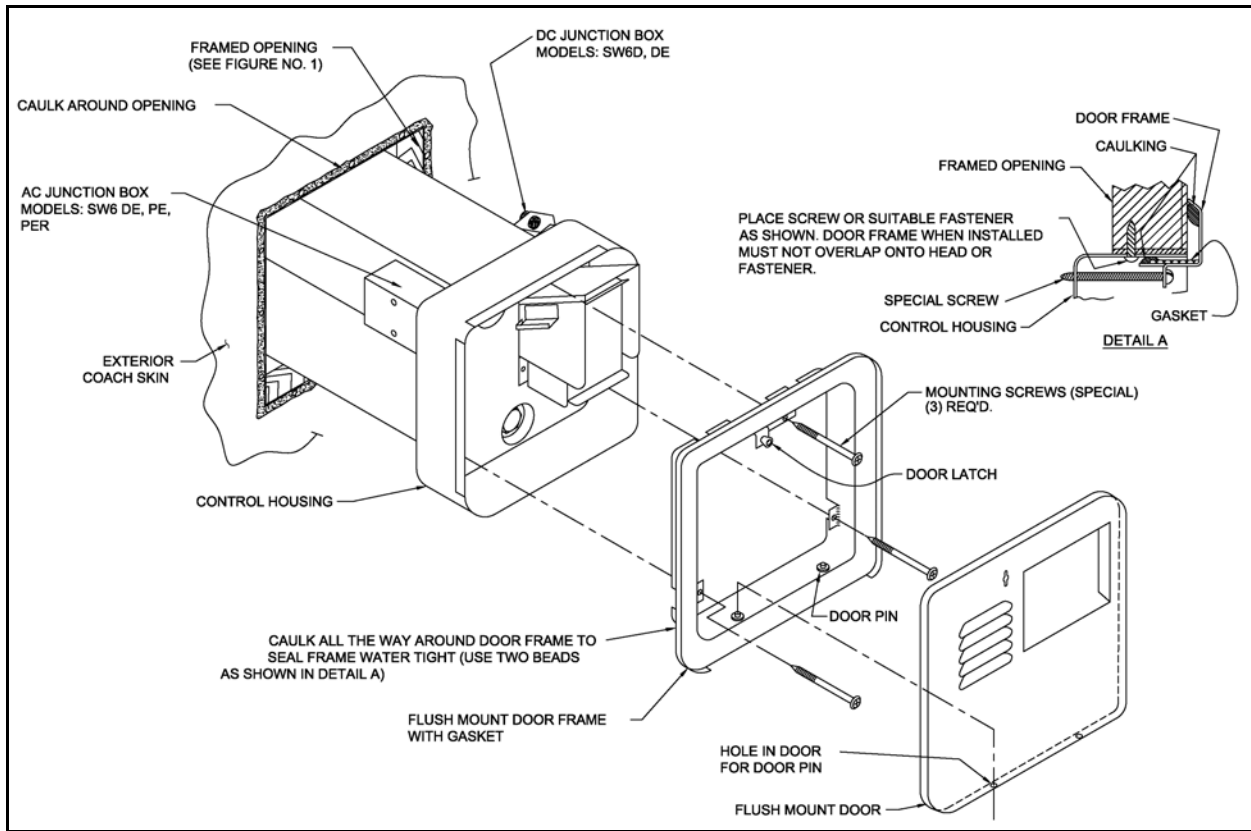

Figure 2

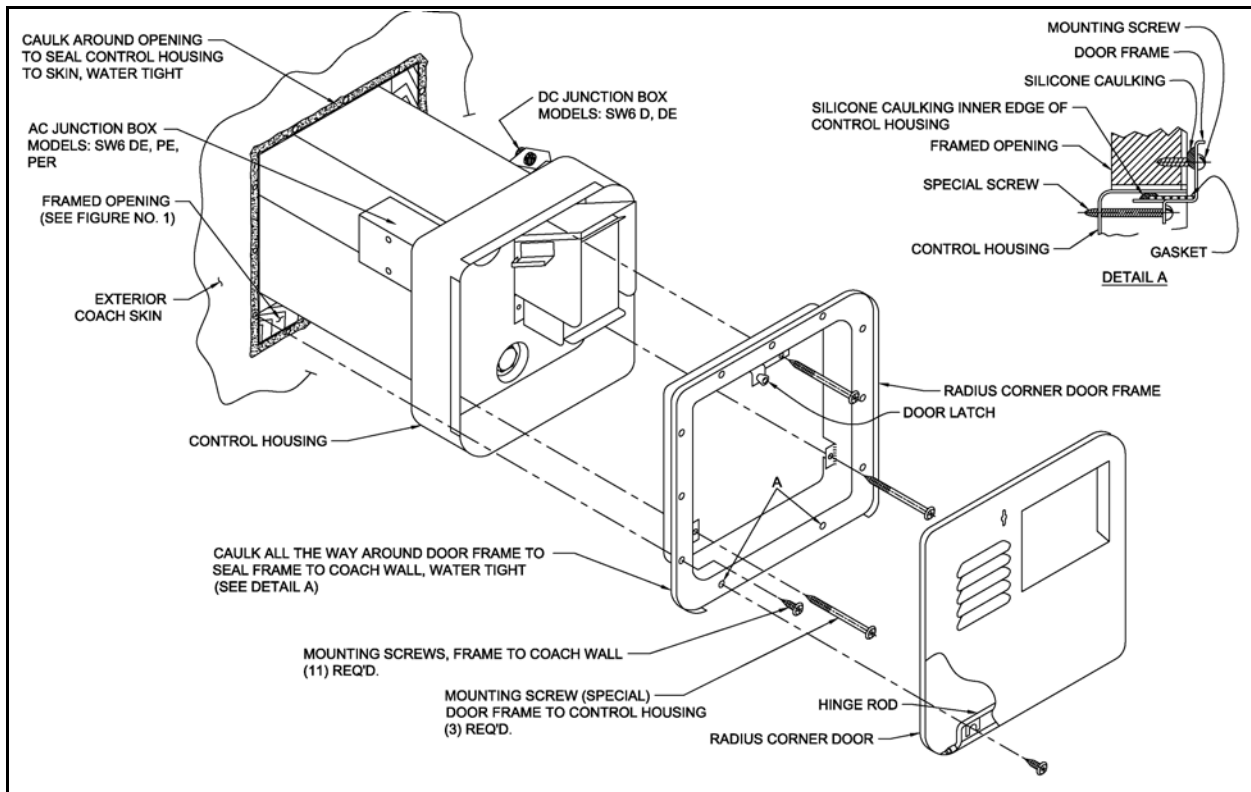

Figure 3

MAKING WATER CONNECTIONS

A. Water connections are made at the rear of the water heater. Refer to Figure 4 for all models except SW 6DM and SW 6DEM. For SW 6DM and SW 6DEM, refer to Figure 5 or 6. Connect the hot and cold water lines to the 1/2" female pipe fitting provided on rear of tank. These fittings are marked "HOT" and "COLD". **NOTE:** Inside each fitting is a plastic fill tube. Its purpose is to enhance water circulation. **DO NOT REMOVE PLASTIC FILL TUBE.**

IMPORTANT: Use a pipe thread compound suitable for potable water or pipe thread tape on all connections to assure they will not leak.

B. For ease of removal, it is suggested that a pipe union be installed in each water line.

C. Fill tank with water. Open both hot and cold water faucets to expel air from tank. When tank is filled and water flows from faucets, close both faucets and check all connections for leaks.

CAUTION: If you use air pressure to check for leaks, the pressure must not exceed 30 PSI (in accordance with 4-9.1.1 of ANSI A119.2).

NOTE: After leak testing, drain water from tank.

MAKING GAS CONNECTIONS

A. Connect a 3/8" gas supply line to the 3/8 flare fitting at gas valve located in the control housing. When making the gas connection, hold the gas fitting on the valve with a wrench when tightening the flare nut. Failure to hold fitting secure could result in a gas leak due to fitting being damaged. **NOTE:** It will be necessary to remove the grommet from the control housing, make the gas connection at the valve, then reinstall grommet.

WARNING! It is imperative that grommet and gas line through grommet be caulked air tight. If not tightly sealed, moisture and potential harmful flue products could vent through opening and into living area of trailer. (See Figure 7.)

B. Turn on gas and check all fittings and connections for leaks, using a soap and water solution. Correct even the slightest leak immediately.

WARNING! Do not use an open flame to check for leaks!

HIGH ALTITUDE DERATING

Suburban water heaters are certified by nationally recognized testing laboratories for operation without modifications at altitudes up to 4,500 feet. Operation above this elevation may require derating by 4 percent for every 1,000 feet above sea level. For example, at 8,000 feet, the water heater should be derated approximately 32 percent.

If the unit is not properly derated, lack of sufficient oxygen for combustion may produce improper burner operation. Pilot outage caused by burner lift-off or sooting from a yellow burner may occur indicating the possibility of carbon monoxide. You may also notice a lack of efficiency in heating the water because of incomplete combustion of the burner at these higher altitudes.

Consult with the local gas company, your dealer, an RV service agency or Suburban Manufacturing Company for proper derating of the unit. Change-out of the orifice (derating) should be done by the dealer or a qualified service agency.

NOTE: It is important that once the unit has returned to lower elevation (below 4,500 feet), this high altitude derating and pilot adjustments (if equipped) be reversed for proper operation of the unit.

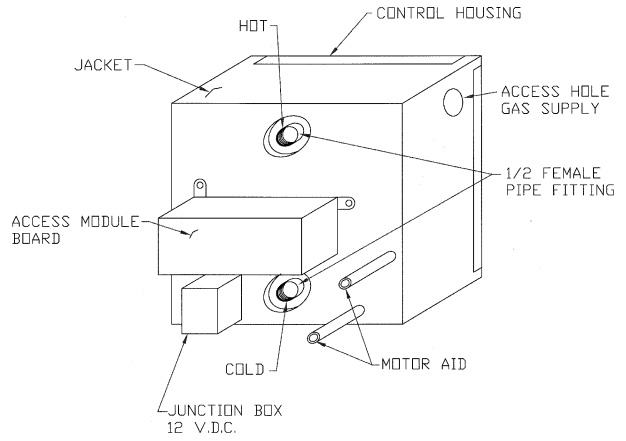

Model SW6DM
Figure 5

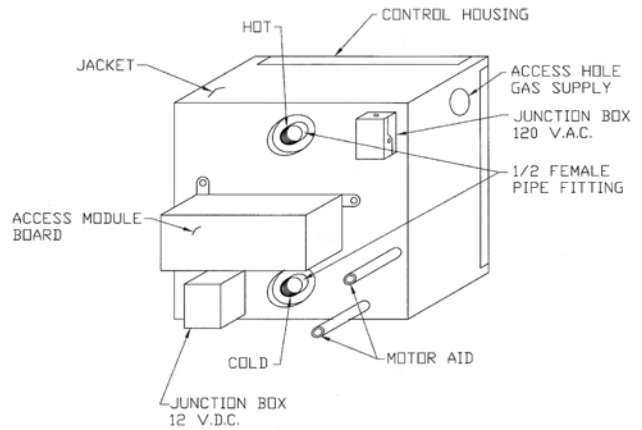

Model SW6DEM
Figure 6

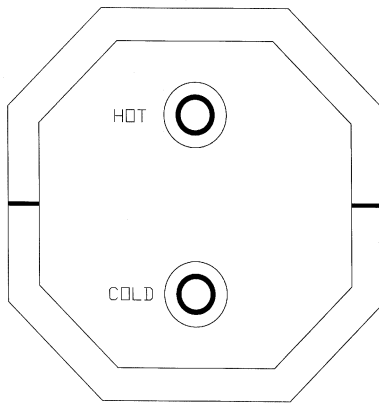

Figure 4

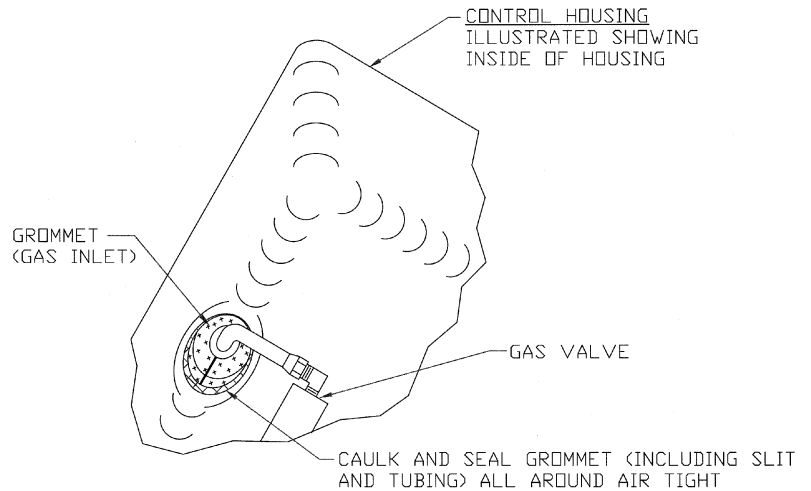

Figure 7

MAKING ELECTRICAL CONNECTIONS 12 VOLTS D.C.

- A. Applicable to following models: SW6D, SW6DE, SW6DM and SW6DEM.
- B. Refer to Figure 2 for location of D.C. junction box on models SW6D and SW6DE. Refer to Figure 5 and 6 for location of D.C. junction box on models SW6DM and SW6DEM.
- C. The electrical connections must be made in accordance with local codes and regulations. In the absence of local codes and regulations, refer to the latest edition of the National Electrical Code ANSI/NFPA No. 70.
- In Canada, the electrical installation should conform with CSA standard CSA C22.2 No. 148/Z240.6.2 Electrical Requirements for Recreational Vehicles and CSA C22.1 Canadian Electrical Code Part 1 when installing the unit in recreational vehicles and mobile homes respectively.
- D. Make the 12 Volt D.C. electrical connections following the wiring diagram illustrated in Figure 8.

If the power supply is to be from a convertor, we recommend that the converter system be wired in parallel with the battery. This will serve two purposes:

1. Provide a constant voltage supply
2. Filter any A.C. spikes or volt surges

We recommend insulated terminals be used for all electrical connections.

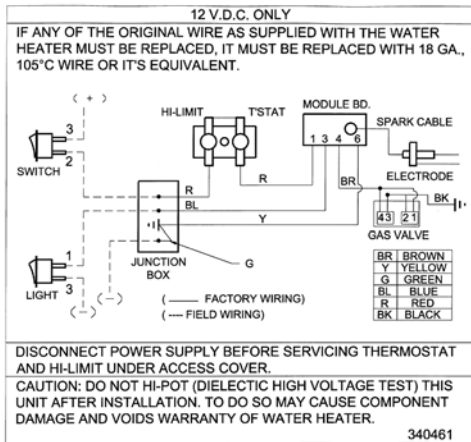

Figure 8
**MAKING ELECTRICAL CONNECTIONS
120 VOLTS A.C.**

- A. Applicable to following models SW6DE and SW6DEM.
- B. Refer to Figure 2 for location of A.C. junction box on model SW6DE. Refer to Figure 6 for A.C. junction box on model SW6DEM.
- C. The electrical connections must be made in accordance with local codes and regulations. In the absence of local codes and regulations, refer to the latest edition of the National Electrical Code ANSI/NFPA No. 70.
- In Canada, the electrical installation should conform with CSA standard CSA C22.2 No. 148/Z240.6.2. Electrical requirements for Recreational Vehicles and CSA C22.1 Canadian Electrical Code Part 1 when installing the unit in recreational vehicles and mobile homes respectively.
- D. Check rating plate and wiring diagram (Figure 9) before proceeding. Install a fused safety switch or circuit breaker of adequate capacity between heater and electrical power source. Attach the black and white wires from the fused switch or breaker to corresponding colored wires in heater junction box. A green wire from a well grounded source must be attached to the green nut in the junction box.
- CAUTION: Before applying the 120 VAC power to the water heater junction box, be sure the switch for electric element is in the "OFF" position.**

WARNING! Before the switch for the electric element is turned to the "ON" position, the water heater tank must be filled with water. See "Safety Warnings".

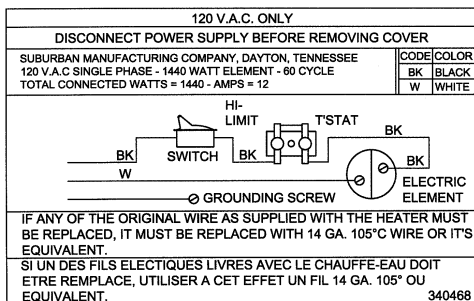

Figure 9

INSTALLATION OF MOTOR AID HEAT EXCHANGER

- A. Place copper "Y"s in heater as shown in Figure 10.
- B. Secure hoses to "Y"s with hose clamps.
- C. Attach hose from motor-aid heat exchanger to "Y"s.
- D. Secure hoses to motor-aid and "Y"s with clamps.
- E. Check all connections for water leaks and proper water circulation through motor-aid heat exchanger, with engine running.
- The system should be checked annually for deterioration of heater hose and hose connections. Replace as needed.

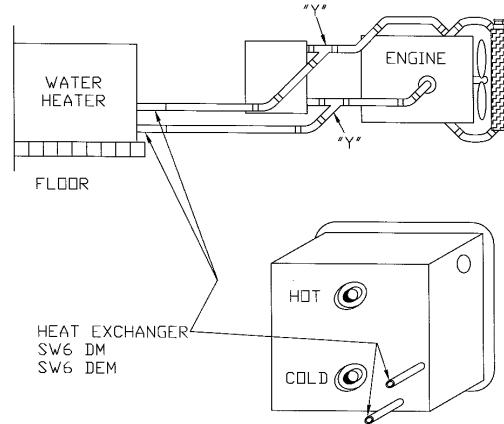

Figure 10

MAINTENANCE

WARNING! If the user of this appliance fails to maintain it in the condition in which it was shipped from the factory or if the appliance is not used solely for its intended purpose or if appliance is not maintained in accordance with the instructions in this manual, then the risk of a fire and/or the production of carbon monoxide exists which can cause personal injury, property damage or loss of life.

WARNING: For your safety, all repairs should be performed by your dealer or a qualified service person.

- A. Main Burner: Do not allow the burner to burn with a yellow flame, because sooting will occur. (See Safety Warnings). If the burner flame is yellow and has an erratic pattern, shut unit down and contact a qualified service agency. Do not continue operating unit with improper burner flame. (See Figure 11 for correct and incorrect burner flame appearance.)
- B. Periodically inspect unit for soot. If soot is present anywhere on water heater, immediately shut unit down and contact your dealer or a qualified service person. Soot is a sign of incomplete combustion and must be corrected before operating water heater. Areas to check would include:
1. Check for an obstruction in burner or the flue box.
 2. Check the screen in the door to see that no foreign material has accumulated to prevent flow of combustion and ventilating air.
 3. Check to be sure there is no flame present at burner orifice or burner whenever main gas valve is closed. This can be checked by turning the OFF/ON switch to the "OFF" position.
- C. Frequent checks should be made of the grommet on the gas inlet to assure tight seal. (See "Making Gas Connections").
- D. Periodically check wiring and wire connection to be sure wiring is not damaged/frayed and that all terminals and connections are tight and in compliance with codes (See "Making Wire Connections").

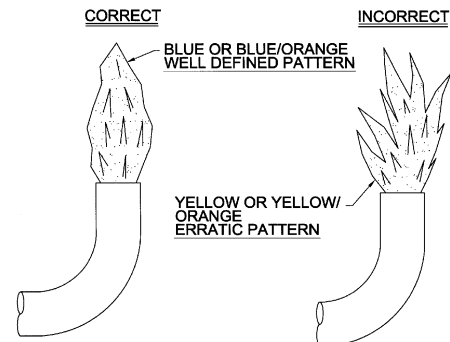

Figure 11

SAFETY WARNINGS

WARNING! It is imperative that the water heater tank be filled with water before operating the water heater. Operation of the water heater without water in the tank may result in damage to the tank and/or controls. This type of damage is not covered by the limited warranty.

WARNING! Hydrogen gas may result if you have not used this heater for two weeks or more. **HYDROGEN GAS IS EXTREMELY FLAMMABLE.** To reduce the risk of injury under these conditions, open the hot water faucet for several minutes at the kitchen sink before you use any electrical appliance connected to the hot water system. If hydrogen is present, you probably will hear an unusual sound such as air escaping through the pipe as the water begins to flow.

Hydrogen gas may be present even after water has been drained from the tank. Open faucet at sink and allow system to vent for several minutes (5-10 minutes).

Do not smoke or have any open flame near the open faucet. Do not attempt to light pilot or main burner. On DSI models, be sure the switch is "OFF".

Should overheating occur, or the gas supply fail to shut off, shut off the manual gas valve to the appliance before shutting off the electrical supply. Do not use this appliance if any part has been submerged under water. Immediately call a qualified service technician to inspect the appliance and to replace any part of the control system and any gas control that has been submerged under water.

Do not alter the operation of your water heater nor change the design/construction of your water heater. Accessories are being marketed for RV products which we do not recommend. For your safety, only factory authorized parts are to be used on your water heater.

Periodically inspect the vent for obstructions or presence of soot. Soot is formed whenever combustion is incomplete. This is your visual warning that the water heater is operating in an unsafe manner. If soot is present, immediately shut the water heater down and contact your dealer or a qualified service person.

When considering add-on rooms, porch or patio, attention must be given to the venting of your water heater. For your safety, do not terminate the vent on your water heater inside add-on rooms, screen porch or onto patios. Doing so will result in products of combustion being vented into the rooms or occupied areas.

Never operate the heater if you smell gas. Do not assume that the smell of gas in your RV is normal. Any time you detect the odor of gas, it is to be considered life threatening and corrected immediately. Extinguish any open flames including cigarettes and evacuate all persons from the vehicle. Shut off gas supply at LP gas bottle. (See Safety notice on front cover of this manual.)

NOTE: Always open both the cold and hot water faucets when filling vehicle water tank to allow air pockets to be forced out of the water heater. When water flows from the heater faucets, close both faucets.

WARNING! Do not store or use combustible materials or liquids near or adjacent to this heater. The appliance shall not be installed in any location where flammable liquids or vapors are likely to be present.

Be sure the power is "OFF" to the water heater ignition system during any type of refueling and while vehicle is in motion or being towed.

The thermostat on your water heater is not adjustable. It is a temperature sensing limit designed to maintain a water temperature of 130°F (54°C). Water temperatures over 130°F (54°C) can cause severe burns instantly or death from scalds; therefore, be careful when using hot water. Children, disabled and elderly are at highest risk of being scalded. Always feel water before bathing or showering.

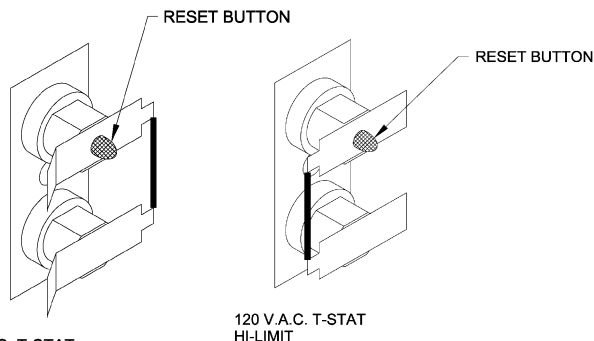

12 V.D.C. T-STAT
HI-LIMIT

120 V.A.C. T-STAT
HI-LIMIT

Figure 13

Figure 13

ANODE PROTECTION

The tank in this water heater is protected by a magnesium or aluminum anode to prolong the life of the tank by absorbing the corrosive action of hot water. Under normal use, the anode rod will deteriorate and because of this, we recommend it be replaced yearly. **NOTE:** Water with high levels of iron and/or sulfate will increase the rate of deterioration; therefore, more frequent replacement may be required. If anode rod is mostly eaten away, replace it with a new one. (See Figure 12)

To prevent a water leak when replacing the anode rod, a pipe thread sealant approved for potable water (such as Teflon tape) must be applied to the threads of the anode rod. Proper application of a thread sealant will not interfere with the anode's tank protection.

Operating the water heater without proper anode protection will decrease tank life and will void your warranty on the tank. **NOTE:** Tank is drained by removing anode rod (See "Drain and Storage" instructions).

To extend anode life, drain water from tank whenever RV is not being used. Avoid any extended time of non use with water in tank.

Also, refer to section on winterizing.

WARNING! Do not replace the anode rod with any non-Suburban accessory part, such as an "add-on" electric heating element. Items such as these are not approved to be installed in Suburban products. They could create an unsafe condition and will also void all warranties.

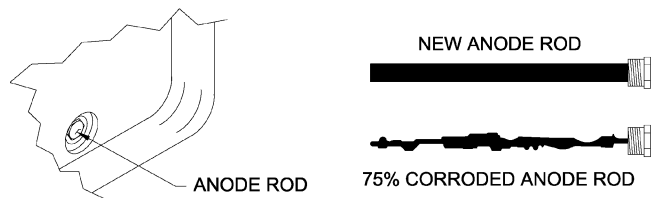

Figure 12

PRESSURE RELIEF VALVE

The temperature and pressure relief valve is designed to open if the temperature of the water within the heater reaches 210°F, or if the water pressure in the heater reaches 150 pounds. Recreational vehicle water systems are closed systems and during the water heating cycle the pressure build-up in the water system will reach 150 pounds. When this pressure is reached, the pressure relief valve will open and water will drip from the valve. This dripping will continue until the pressure is reduced to below 150 pounds, and the valve closes. This condition is normal and does not indicate a defective relief valve.

WARNING! Do not place a valve between the relief valve and the tank. Do not plug the relief valve under any circumstances.

WATER WEeping OR DRIPPING FROM PRESSURE RELIEF VALVE

You may experience water weeping or dripping from your water heater's Pressure and Temperature (P & T) Relief Valve when your water heater is operating. Water weeping or dripping from the P & T Valve does not always mean the P & T Valve is defective. As water is heated, it expands. The water system in a recreational vehicle is a closed system and does not allow for the expansion of heated water. When the pressure of the water system exceeds the relieving point of the P & T Valve, the valve will relieve the excess pressure.

Suburban recommends that a check valve not be installed directly at the inlet to the water heater tank. This will increase weeping of the pressure relief valve.

WARNING! Do not remove or plug the relief valve.

One way to reduce the frequency of this occurrence is to maintain an air pocket at the top of the water heater tank. This air pocket will form in the tank by design. However, it will be reduced over time by the everyday use of your water heater.

To replenish this air pocket:

1. Turn off water heater.
2. Turn off cold water supply line.
3. Open a faucet in the RV.
4. Pull out on the handle of the Pressure Relief (P & T) Valve and allow water to flow from the valve until it stops.
5. Release handle on P & T Valve - it should snap closed.
6. Close faucet and turn on cold water supply; as the tank fills, the air pocket will develop.

Repeat this procedure as often as needed to reduce the frequency of the weeping of the P & T Valve. If the weeping persists after following this procedure, you may elect to install an expansion or accumulator tank in the cold water line between the tank and check valve to relieve the pressure caused by thermal expansion. Contact your local dealer for assistance.

THERMOSTAT AND MANUAL RESET

MODELS: SW6D, SW6DE, SW6DM and SW6DEM (See Figure 13)

The model water heaters listed above are equipped with a high temperature limit as a cut-off device. Temperature above 180°F will cause manual reset button to trip shutting down main burner.

To activate burner, the water temperature must be below 110°F, push reset button to re-activate burner.

THERMOSTAT AND MANUAL RESET

MODELS SW6DE and SW6DEM (See Figure 14)

The model water heaters listed above are equipped with a high temperature limit as a cut-off device. Temperature above 180°F will cause manual reset button to trip shutting down the electric element.

To activate element, the water temperature must be below 110°F, push reset button to re-activate the electric element.

DRAINING AND STORAGE INSTRUCTIONS

If RV is to be stored during winter months, the water heater must be drained to prevent damage from freezing.

1. Turn off electrical power to water heater either at the switch from the electrical element or at breaker.
2. Shut off gas supply to water heater.
3. Turn off pressure pump on water system.
4. Open both hot and cold water faucets.
5. Remove anode rod from tank.
6. Follow RV manufacturer's instructions for draining entire water system.

NOTE: Be certain to refill water heater with water and remove all air from tank and lines before re-lighting or before turning on electrical power.

ODOR FROM HOT WATER SYSTEM

Odor from the hot water system is not a service problem and many water supplies contain sufficient amounts of sulphur to produce an odor. The odor is similar to rotten eggs and is often referred to as "sulphur water". It is not harmful - only unpleasant to smell. Sulphur water can be caused by a chemical action or by bacteria. The solution to eliminate is chlorination of the water system. Add about six (6) ounces of chlorinated common household liquid bleach to each 10 gallons in the water tank. Then run the chlorinated water throughout the system,

opening each faucet one at a time until you smell the chlorine. Let the RV sit for a few days and the chlorine should take care of the problem. Then you will need to take care of the chlorine. Remove the chlorine by flushing the system with fresh water. This may take several attempts. You may consider adding a filtering system that removes chlorine and prevents sulphur water. If the sulphur or rotten egg smell continues, flush the system once again as described above and replace anode rod as necessary.

REMOVING WATER HEATER

1. Shut off gas supply and disconnect gas supply line from water heater.
2. On all Electric Models, disconnect 120 V.A.C. supply at junction box mounted on heater.
3. On all DSI Models, disconnect 12 V.D.C. power supply at junction box on heater.
4. On Models SW6D and SW6DE disconnect all wires at module board.
5. Shut off water supply. Drain water from tank following instructions under "Draining and Storage".
6. Disconnect hot and cold water lines from water heater.
7. Remove screws or nails securing control housing to framed opening.
8. Slide heater out. To reinstall, follow instructions in manual under "Installation Instructions".

WINTERIZING

If your water heater plumbing system is equipped with a bypass kit, use it to close off the water heater, drain the water heater completely and leave the water heater closed off (out of the system) in the bypass position *particularly* if you are introducing antifreeze into the plumbing system. Antifreeze can be very corrosive to the anode rod creating premature failure and heavy sediment in the tank. If the plumbing system is not equipped with a bypass kit, and you intend to winterize by adding antifreeze to the system, remove the anode rod (storing it for the winter) and replace it with a 3/4" drain plug.

FOR YOUR SAFETY READ BEFORE OPERATING

WARNING! If the user of this appliance fails to maintain it in the condition in which it was shipped from the factory or if the appliance is not used solely for its intended purpose or if appliance is not maintained in accordance with the instructions in this manual, then the risk of a fire and/or the production of carbon monoxide exists which can cause personal injury, property damage or loss of life.

OPERATING INSTRUCTIONS

WARNING! If you do not follow these instructions exactly, a fire or explosion may result causing property damage, personal injury or loss of life.

WARNING: Before operating water heater, be sure tank is filled with water. See "Safety Warnings".

- A. This appliance does not have a pilot. It is equipped with an ignition device which automatically lights the burner. Do not try to light the burner by hand.
- B. BEFORE LIGHTING smell all around the appliance area for gas. Be sure to smell next to the floor because some gas is heavier than air and will settle on the floor.

WHAT TO DO IF YOU SMELL GAS

- Do not try to light any appliance.
 - Do not touch any electric switch.
 - Do not use any phone in your building.
 - Immediately call your gas supplier from a neighbor's phone. Follow the gas supplier's instructions.
 - If you cannot reach your gas supplier, call the fire department.
- C. This is an automatic gas valve, no adjustments are necessary. Do not attempt to repair the gas valve. This may result in a fire or explosion.
 - D. Do not use this appliance if any part has been under water. Immediately call a qualified service technician to inspect the appliance and to replace any part of the control system and any gas control which has been under water.
 - E. Before operating water heater, check the location of the vent to make sure it will not be blocked by the opening of any door on the trailer. If it can be blocked, do not operate the water heater with the door open.

OPERATING INSTRUCTIONS

1. STOP! Read the safety information provided.
2. Turn off all electric power to the appliance.
3. Turn "OFF" gas supply.
4. Wait five minutes for gas to clear the area. If you smell gas then STOP! Follow instructions in item B of the safety information. If you don't smell gas, go to next step.
5. Turn "ON" gas supply.
6. Turn on electrical power to the appliance.
7. Turn switch to "ON" position. If the burner does not light, the system will automatically attempt two more tries for ignition before lock-out.

NOTE: Each ignition cycle will have a 15 second purge before spark cycle if system is a three try system.

8. If lockout occurs before main burner lights, turn switch to "OFF", wait five seconds and turn switch to "ON" position. This will restart the ignition cycle. The first start-up of the heater may require several ignition cycles before all air is purged from the gas lines.

If the burner will not come on, the following items should be checked before calling a service person.

1. Switch turned off.
2. Gas supply to heater is empty or turned off.
3. Reset button on ECO is tripped.

OPERATING INSTRUCTIONS FOR UNITS WITH ELECTRIC ELEMENT

Electric water heaters are designed to operate with a minimum amount of service problems; however, proper operation and care is essential.

By far the most common trouble with electric water heaters results from energizing the water heater before it is filled with water. Even brief operation of the electric element without water in the tank will burn-out the electric heating element.

To energize the electric heating element, turn the switch to "ON". The switch is located behind the water heater door in the lower left corner of the control housing. The water temperature will be regulated by the thermostat.

TO TURN OFF WATER HEATER

1. Turn switch to "OFF" position.
2. Turn off electrical power to the appliance.
3. Turn off gas supply.
4. If vehicle is to be stored or heater is going to be turned off while subject to freezing temperature, drain water heater. (See "Draining and Storage Instructions.")

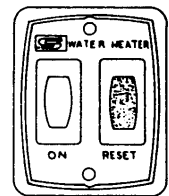

PARTS ILLUSTRATION AND REPLACEMENT PARTS LIST

Only factory authorized parts are to be used. Do not attempt to repair defective parts.

When ordering repair parts from your dealer or a distributor, always give the following information:

1. Part Number (Not Item No.)
2. Part Description
3. Model No. and Serial No. of your Heater
4. Number of Parts Required

PARTS LIST FOR MODELS SW6D • SW6DE (Figure 15)

Item No.	Description	Part Number	
		SW6D	SW6DE
1	Module Board	520814	520814
3	Cover, Module Board	090487	090487
6	Bushing, Snap 1/2"	070270	070270
7	Bushing, Strain Relief 5/8"	230216	230216
8	D.C. Junction Box Assembly	090517	090517
10	Back Assembly, Flue Collector	101682	101682
11	Front, Flue Collector	101776	101776
12	Valve, Pressure Relief	161157	161157
13	Screw #10 x 1/4	121577	121577
15	Cover, Thermostat/Hi-Limit	090562	090562
16	Gasket, Thermostat Cover	070987	070987
18	Grommet	070874	070874
20	Bracket, Electrode Mounting	063187	063187
21	Electrode	232258	232258
24	Cover, Element	-----	090445
25	Gasket, Element Cover	-----	070988
26	Burner Assembly with orifice	010843	010843
28	Electric Element with Gasket	-----	520789
29	Anode	232767	232767
31	Grommet	071246	071246
32	Bushing, Snap 1/2"	-----	070270
33	Switch, Electric Element	-----	232362
34	Gas Fitting	170374	170374
35	Bracket, Valve Mounting	063243	063243
36	Valve, Gas (LP)	161109	161109
37	Manifold, Outlet	171420	171420
38	#10 x 1/4 (4 Required)	121577	121577
39	Screw #8-32 x 3/8 Hex HD. (2 Required)	121958	121958
41	Switch Assembly, 12 V.D.C. T-Stat/Hi-Limit	232282	232282
42	Switch Assembly, 120 V.A.C. T-Stat/Hi Limit	-----	232306
44	Cover, Junction Box	-----	090576
45	Grommet, Gas Inlet	070989	070989
46	Bushing, Snap 7/8"	-----	230218
47	A.C. Junction Box Assembly	-----	090575
48	Nut, 10-24 Keps (Green)	121576	121576
49	Bushing, Snap 7/8"	-----	230218
50	Foam Jacket Assembly Complete	520868	520868
51	Switch, Lamp and Plate Assembly	232589	232589
52	Screw 8mm - 4.0 x 1/2 Hex Washer Head (2 Required)	121943	121943
53	Burner Bracket	063444	063444
55	1/4 Loxit Nut (Manifold to Burner)	171463	171463
56	1/4 Loxit Nut (Manifold to Valve)	171463	171463
57	Electrode Wire (Not Shown)	232456	232456

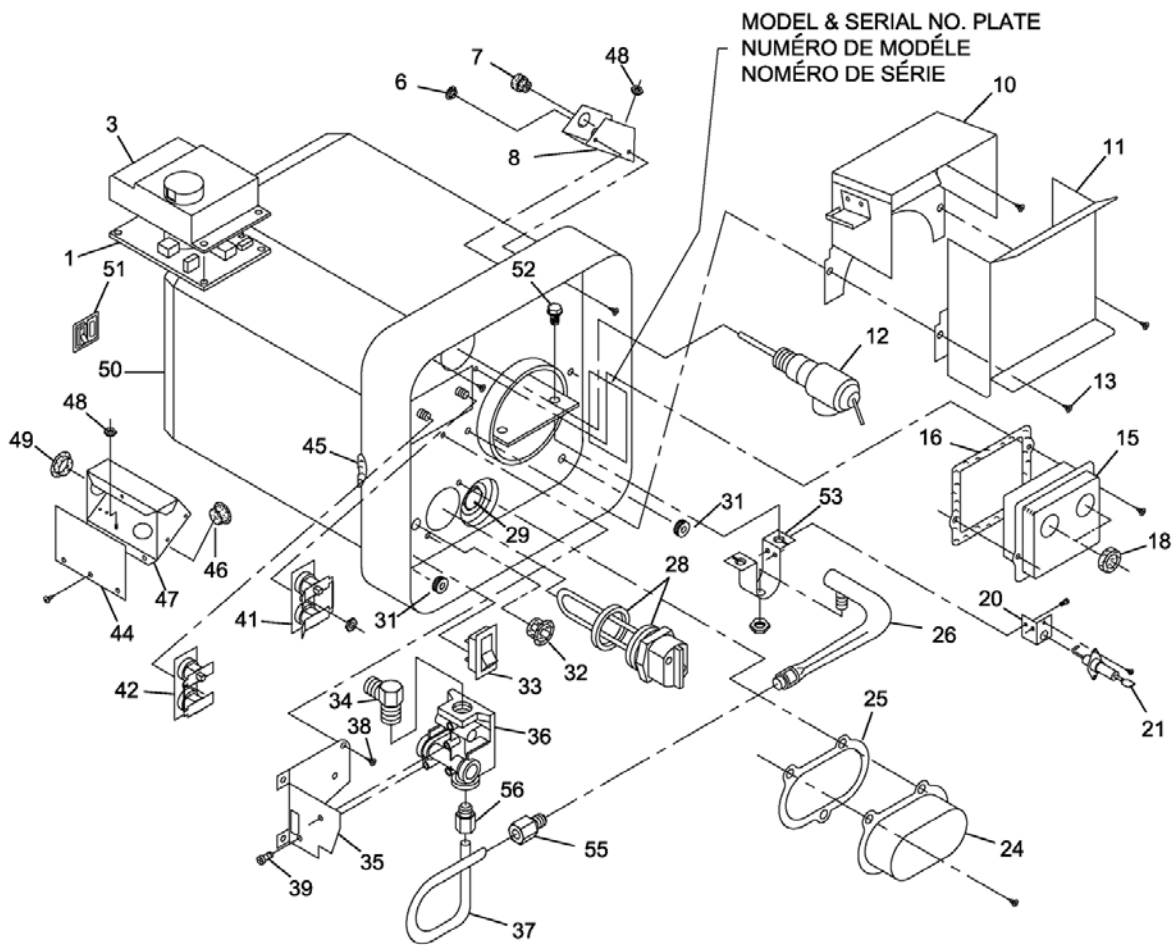
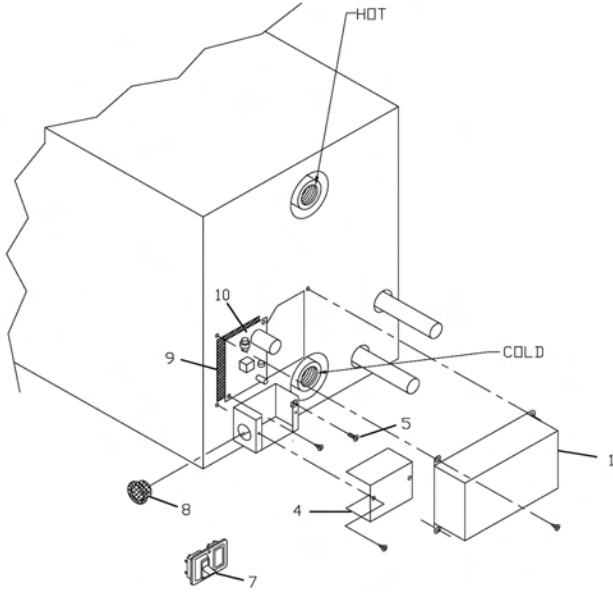

Figure 15

**PARTS LIST FOR MODEL SW6DM
(Figures 16 and 17)**

Item No.	Description	Part Number SW6DM	Item No.	Description	Part Number SW6DM
1	Cover, Module Board	090340	21	Electrode	232258
4	Cover Junction Box	090344	22	Bracket, Electrode Mounting	063187
5	Screw 10-32 x 3/8 (Green)	121702	23	Burner Assembly with orifice	010843
7	Switch, Lamp and Plate Assembly	232589	25	1/4 Loxit Nut (Manifold to Valve)	171463
8	Bushing, Snap 7/8"	230218	26	Valve, Gas (LP)	161109
9	Insulator, Module Board	070807	27	Manifold Outlet	171420
10	Module Board	520814	28	Screw 10 x 1/4 (4 Required)	121577
11	Back Assembly, Flue Collector	101682	29	Screw 8-32 x 3/8 Hex HD (2 Required)	121958
12	Valve, Pressure Relief	161157	30	Bracket, Valve Mounting	063243
13	Gasket, Thermostat Cover	070987	31	Gas Fitting	170374
14	Cover, Thermostat/Hi-Limit	090562	32	Switch Assembly 12 V.D.C. T-Stat/Hi-Limit	232282
17	Front, Flue Collector	101776	34	Grommet	071246
18	Screw 10 x 1/4	121577	36	Anode	232767
19	Grommet	070874	37	Grommet, Gas Inlet	070989
			38	Screw 8mm - 4.0 x 1/2 Hex Washer Head (2 Required)	121943
			39	Burner Bracket	063444
			41	1/4 Loxit Nut (Manifold to Burner)	171463
			42	Electrode Wire (Not Shown)	232454



**REAR VIEW
SW6DM**

Figure 16

**REAR VIEW
SW10 DM**

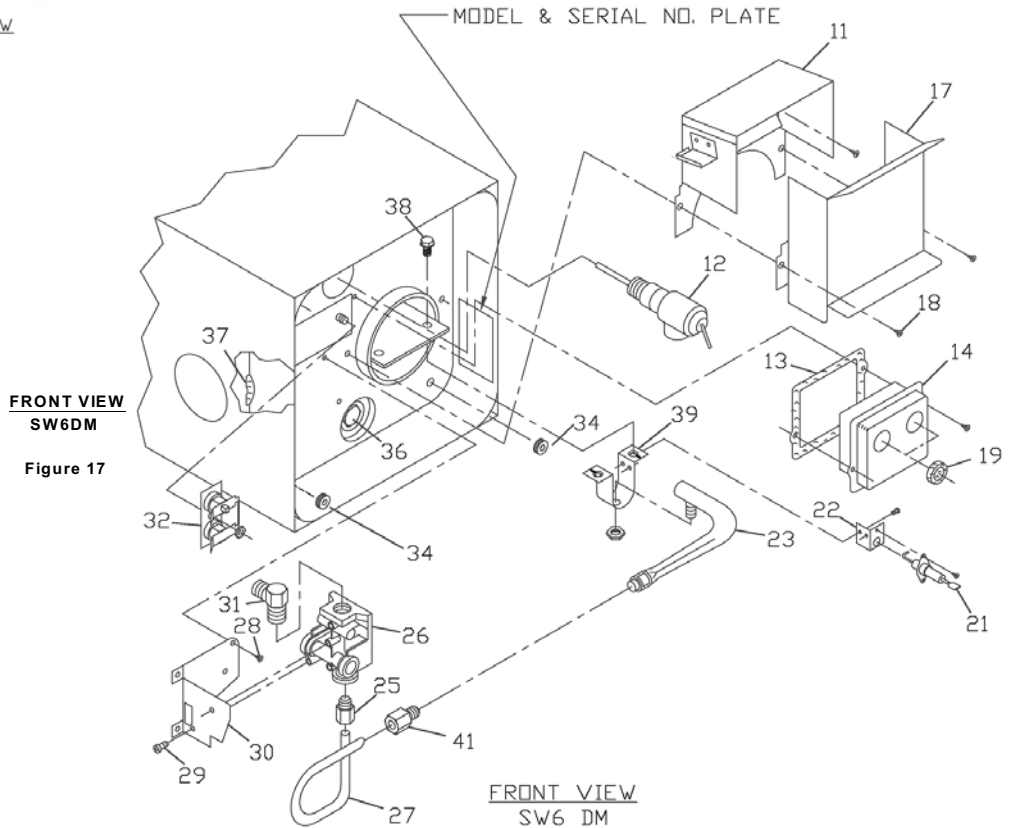

**FRONT VIEW
SW6DM**

Figure 17

**FRONT VIEW
SW6 DM**

PARTS LIST FOR MODEL SW6DEM (Figures 18 and 19)

Item No.	Description	Part Number SW6DEM	Item No.	Description	Part Number SW6DEM
1	Cover, Module Board	090340	28	Cover, Element	090445
4	Cover, Junction Box (12 V.D.C.)	090344	29	Gasket, Element Cover	070988
5	Screw 10-32 x 3/8 (Green)	121702	30	Burner Assembly with orifice	010843
7	Switch, Lamp and Plate Assembly	232589	32	1/4 Loxit Nut (Manifold to Valve)	171463
8	Bushing, Snap	230218	33	Electric Element with Gasket	520789
9	Insulator, Module Board	070807	34	Anode	232767
10	Module Board	520814	36	Grommet	071246
11	Cover, Junction Box	090464	37	Switch, Electric Element	232362
12	Nut 10-24 Keps (Green)	121576	38	Valve, Gas (LP)	161109
13	Bushing	070486	39	Manifold, Outlet	171420
14	Back, Flue Collector	101682	40	Screw 10 x 1/4 (4 Required)	121577
16	Screw #10 x 1/4	121577	41	Screw #8-32 x 3/8 Hex HD	121958
17	Front, Flue Collector	101776		Bracket, Valve Mounting	063243
18	Valve, Pressure Relief	161157	43	Gas Fitting	170374
19	Gasket, Thermostat Cover	070987	44	Bushing, Snap 1/2"	070270
20	Cover, Thermostat/Hi-Limit	090562	45	Switch Assembly, 120 V.A.C. T-Stat/Hi-Limit	232306
23	Grommet (2 Required)	070874	47	Switch Assembly, 12 V.D.C. T-Stat/Hi-Limit	232282
25	Electrode	232258	48	Grommet, Gas Inlet	070989
26	Bracket, Electrode Mounting	063187	49	Screw 8mm - 4.0 x 1/2 Hex Washer Head (2 Required)	121943
			50	Burner Bracket	063444
			52	1/4 Loxit Nut (Manifold to Burner)	171463
			53	Electrode Wire (Not Shown)	232454

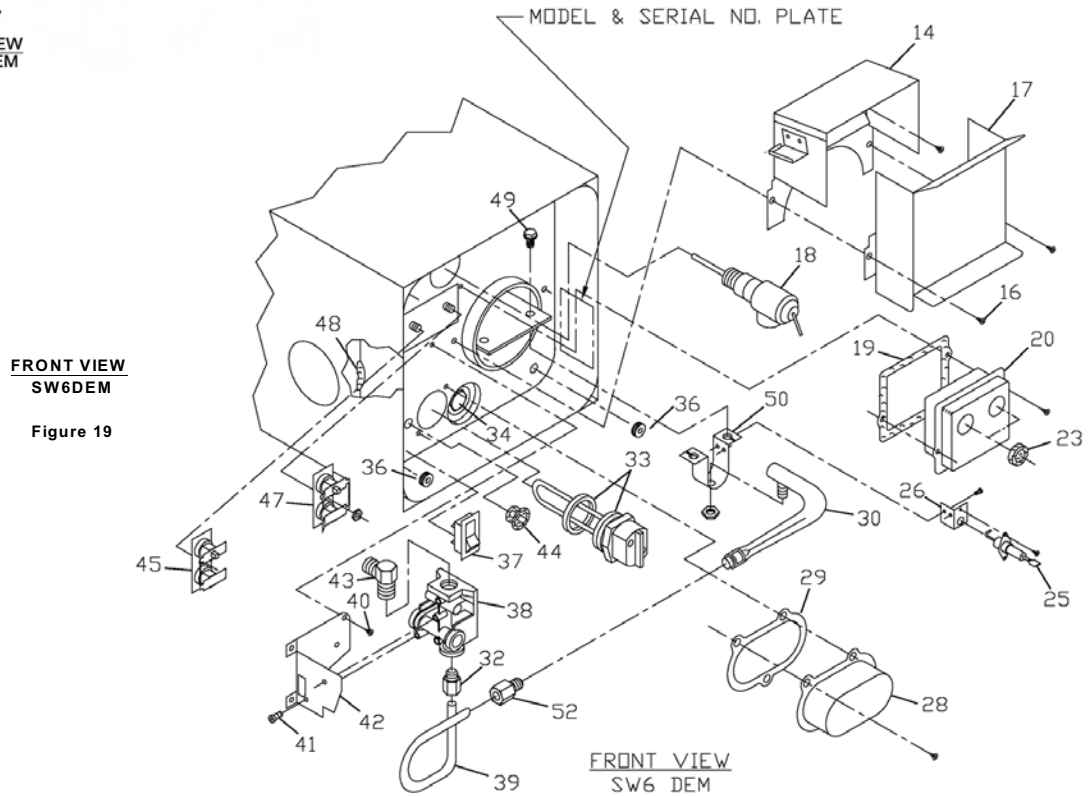
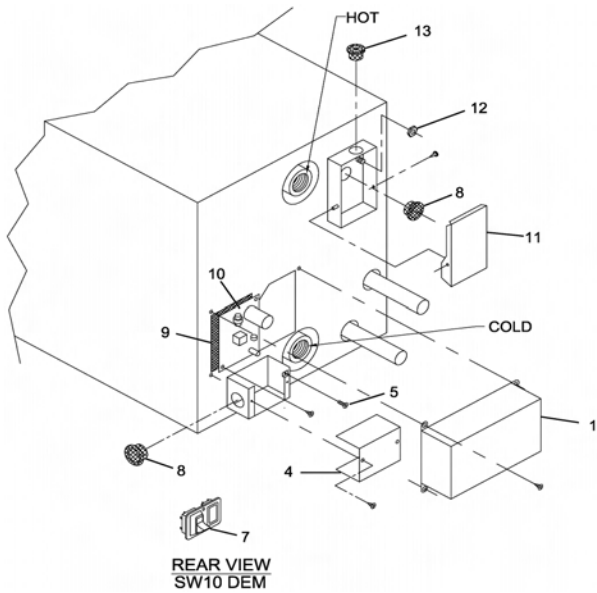

**TWO YEAR LIMITED WARRANTY
SUBURBAN RECREATIONAL VEHICLE WATER HEATER**

TWO YEAR LIMITED WARRANTY

This Suburban product is warranted to the original purchaser to be free from defects in material and workmanship under normal use and maintenance for a period of two years from date of purchase whether or not actual use begins on that date. It is the responsibility of the consumer/owner to establish the warranty period. Suburban does not use warranty registration cards for its standard warranty. You are required to furnish proof of purchase date through a Bill of Sale or other payment records.

Suburban will replace any parts that are found defective within the first two years and will pay a warranty service allowance directly to the recommended Suburban Service Center at rates mutually agreed upon between Suburban and its recommended service centers. Replacement parts will be shipped FOB the shipping point within the Continental United States, Alaska and Canada to the recommended service center performing such repairs. All freight, shipping and delivery costs shall be the responsibility of the owner. The exchanged part or unit will be warranted for only the unexpired portion of the original warranty. Before having warranty repairs made, confirm that the service agency is a recommended service center for Suburban. **DO NOT PAY THE SERVICE AGENCY FOR WARRANTY REPAIRS; SUCH PAYMENTS WILL NOT BE REIMBURSED.**

Suburban reserves the right to examine the alleged defect in the water heater or component parts, and it is the owner's obligation to return the water heater and/or component parts to Suburban or its representative. When returning a water heater, it must include all component parts and the serial number plate. Returned component parts must be individually tagged and identified with the water heater's model number, serial number and date of installation.

For warranty service, the owner/user should contact the nearest recommended Suburban Service Center, advising them of the model and serial numbers (located on the water heater) and the nature of the defect. Transportation of the RV to and from the Service Center and/or travel expenses of the Service Center to your location is the responsibility of the owner/user. A current listing of recommended service center may be obtained from Suburban's website: www.rvcomfort.com. If you cannot locate a recommended service center locally, the service agency chosen to perform warranty repairs must contact our Service Department at 423-775-2131 for authorization before making repairs. Unauthorized repairs made will not be paid by Suburban.

THREE YEAR LIMITED WARRANTY ON TANK

The inner tank is further warranted to be free from defects in material and workmanship during the third year after the date of original purchase. A replacement water heater will be provided under the same conditions as stated in the two year warranty EXCEPT no labor reimbursement will be provided.

LIMITATION OF WARRANTIES

ALL IMPLIED WARRANTIES (INCLUDING IMPLIED WARRANTIES OF MERCHANTABILITY) ARE HEREBY LIMITED IN DURATION TO THE PERIOD FOR WHICH EACH LIMITED WARRANTY IS GIVEN. SOME STATES DO NOT ALLOW LIMITATIONS ON HOW LONG AN IMPLIED WARRANTY LASTS SO THE ABOVE LIMITATIONS MAY NOT APPLY TO YOU. THE EXPRESSED WARRANTIES MADE IN THIS WARRANTY ARE EXCLUSIVE AND MAY NOT BE ALTERED, ENLARGED, OR CHANGED BY ANY DISTRIBUTOR, DEALER OR OTHER PERSON WHOMSOEVER.

SUBURBAN WILL NOT BE RESPONSIBLE FOR:

1. Normal maintenance as outlined in the installation, operating and service instructions owner's manual including cleaning of component parts and cleaning or replacement of the burner orifice. Any water damage arising, directly or indirectly, from any defect in the water heater or component parts or from its use.
 2. Initial checkouts and subsequent checkouts which indicate the water heater is operating properly, or diagnosis without repair.
 3. Damage or repairs required as a consequence of faulty or incorrect installation or application not in conformance with Suburban instructions.
 4. Failure to start and/or operate due to loose or disconnected wires; water or dirt in controls, fuel lines and gas tanks; improper gas pressure; low voltage.
 5. Cleaning or adjustment of components; electrode, burner tube, pilot and thermocouple.
 6. Costs incurred in gaining access to the water heater.
 7. Parts or accessories not supplied by Suburban.
 8. Freight charges incurred from parts replacements.
 9. Damage or repairs needed as a consequence of any misapplication, abuse, unreasonable use, unauthorized alteration, improper service, improper operation or failure to provide reasonable and necessary maintenance.
 10. Suburban products whose serial number has been altered, defaced or removed.
 11. Suburban products installed or warranty claims originating outside the Continental U.S.A., Alaska, Hawaii and Canada.
 12. Damage as a result of floods, winds, lightning, accidents, corrosive atmosphere or other conditions beyond the control of Suburban.
 13. ANY SPECIAL, INDIRECT OR CONSEQUENTIAL PROPERTY, ECONOMIC OR COMMERCIAL DAMAGE OF ANY NATURE WHATSOEVER. Some states do not allow the exclusion of incidental or consequential damages, so the above limitation may not apply to you.
- NO REPRESENTATIVE, DEALER, RECOMMENDED SERVICE CENTERS OR OTHER PERSON IS AUTHORIZED TO ASSUME FOR SUBURBAN MANUFACTURING COMPANY ANY ADDITIONAL, DIFFERENT OR OTHER LIABILITY IN CONNECTION WITH THE SALE OF THIS SUBURBAN PRODUCT.

This warranty gives you specific legal rights, and you may also have other rights which vary from state to state.

IF YOU HAVE A PRODUCT PROBLEM

FIRST:

If your RV has its original water heater and is still under the RV manufacturer's warranty, follow the steps suggested by your dealer or manufacturer of the RV.

SECOND:

Contact a conveniently located recommended Suburban Service Center. Describe to them the nature of your problem, make an appointment, if necessary, and provide for delivery of your RV to the selected service center.

THIRD:

For the location of the nearest Service Center, refer to the listing provided or contact:

Suburban Manufacturing Company
Customer Service Department
676 Broadway Street
Dayton, Tennessee 37321
(423) 775-2131, Ext. 7101
www.rvcomfort.com

For future reference, you should record the following information
MODEL NUMBER _____
SERIAL NUMBER _____
STOCK NUMBER _____
DATE OF PURCHASE _____